

### FEATURES

- Total start-stop feature allows flow to activate electric motor
- Built-in unloader
- Nickel-plated cast manifold manufactured like heavy-duty pump line
- New generation seal package
- New dust protection chamber
- Solid ceramic plungers
- New oversized plunger guide
- New optimized inlet and outlet valves
- New oil seal
- Right side shaft, left side manifold



### SPECIFICATIONS

Pump Model	ET1305E34UTS	ET1504E34UTS	ET1509E17UTS
Maximum Volume	1.6 GPM	2.0 GPM	2.1 GPM
Maximum Discharge Pressure	4,450 PSI	2,610 PSI	
Horsepower	4.9 EBHP	3.6 EBHP	4.9 EBHP
Maximum Pump Speed	3400 RPM		1700 RPM
Maximum Inlet Pressure	125 PSI		
Max. Inlet Vacuum	Flooded		
Plunger Bore (in / mm)	.511 in./13 mm	.591 in./15 mm	
Plunger Stroke (in / mm)	.197 in./5 mm	.157 in/4 mm	.370 in./9.4 mm
Oil Capacity	8.5 oz.		
Maximum Fluid Temperature	165° F		
Inlet Port Thread	1/2"-10 BSP-F		
Discharge Port Thread	3/8"-13 BSP-F		
Shaft Diameter	5/8" Hollow		
Shaft Orientation	Right-hand		
Unloader Orientation	Left-hand		
Weight	11.0 lbs.		
Dimensions - Nominal	8" x 7.4" x 4.7"		

TRIPLEX

TRIPLEX



General Pump  
is a member of  
the Interpump Group



Ref 310085 Rev. C  
02-20



# Instructions and Recommendations for the Installation of *ET Series Pumps*

Maximum temperature of the water through the pump is 165°F (73°C).

In order to obtain maximum performance in terms of duration of seals and valves, it is necessary to respect a few simple rules, as follows:

1) **In order to avoid damage caused by cavitation, the pump must be pressure fed.**

The higher the inlet pressure, the longer the life of the wet end of the pump.

When working at 165°F (73°C), the minimum feed pressure - measured directly in the inlet port of the pump when it is working - is 45 psi (3 bar).

The minimum feed pressure according to the different temperatures are:

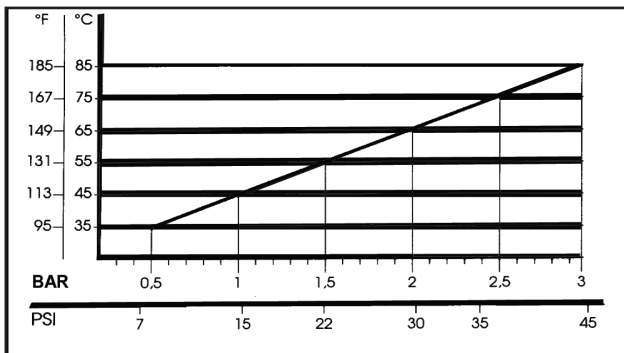

Naturally, if the application allows for feeding the pump with 45 psi (3 bar) even at low temperatures (for example: 115°F/45°C the life of the wet end of the pump will be even longer.

2) **The plumbing which feeds the pump must be of a diameter at least equal to the inlet port.**

Also, follow the suggestions below:

a) Make the plumbing as short and straight as possible, preferably in an upward direction to facilitate the expulsion of eventual air bubbles naturally if compatible with the requirements of the system.

b) It is always useful to put a filter at the inlet with capacity of 4 to 5 times the flow of

the pump, for example for a 4 gpm (15 l/min) pump, put a filter from 16 to 20 gpm (60-75 l/min). The mesh size suitable for this application is 0.016" (.4 mm).

c) It is extremely important to put a pressure switch on the suction port of the pump, and in any case downstream from the filter, so that it can stop the pump should the feed pressure drop by 20% due to the filter clogging or failure of the feed pump, etc.

3) **Change of oil**

We recommend the **first oil change after the first 50 hours**, with the **pump stopped** and the **oil still warm**.

This change is not recommended because the oil has lost its properties, but rather to eliminate the impurities that have gotten into the oil during the running-in phase. If these impurities are not removed, but are allowed to remain in the oil, they *may cause premature wear* to the moving parts and the oil seals. **After this initial change, the oil can then be changed every three months or 300 hours of operation thereafter.**

Please note: If the pump works in conditions with high humidity and with sharp temperature changes, it is possible that condensation will appear inside the crankcase, which mixing with the oil can change its properties. This is easy to see because the oil changes to a white, milky color.



If the pump does not have excessive water leaking from the packings, and the oil becomes milky, the oil has to be changed more frequently. The percentage of water in the oil must not exceed 20%.

**Use oil per the following chart:**

CHART OF COMPATIBLE OILS SAE15W40	
General Pump	Series 100
BP	VISCO 2000
CASTROL	CWX
MOBIL	SUPER
SHELL	HELIX SUPER
TOTAL	QUARTZ 4000-5000

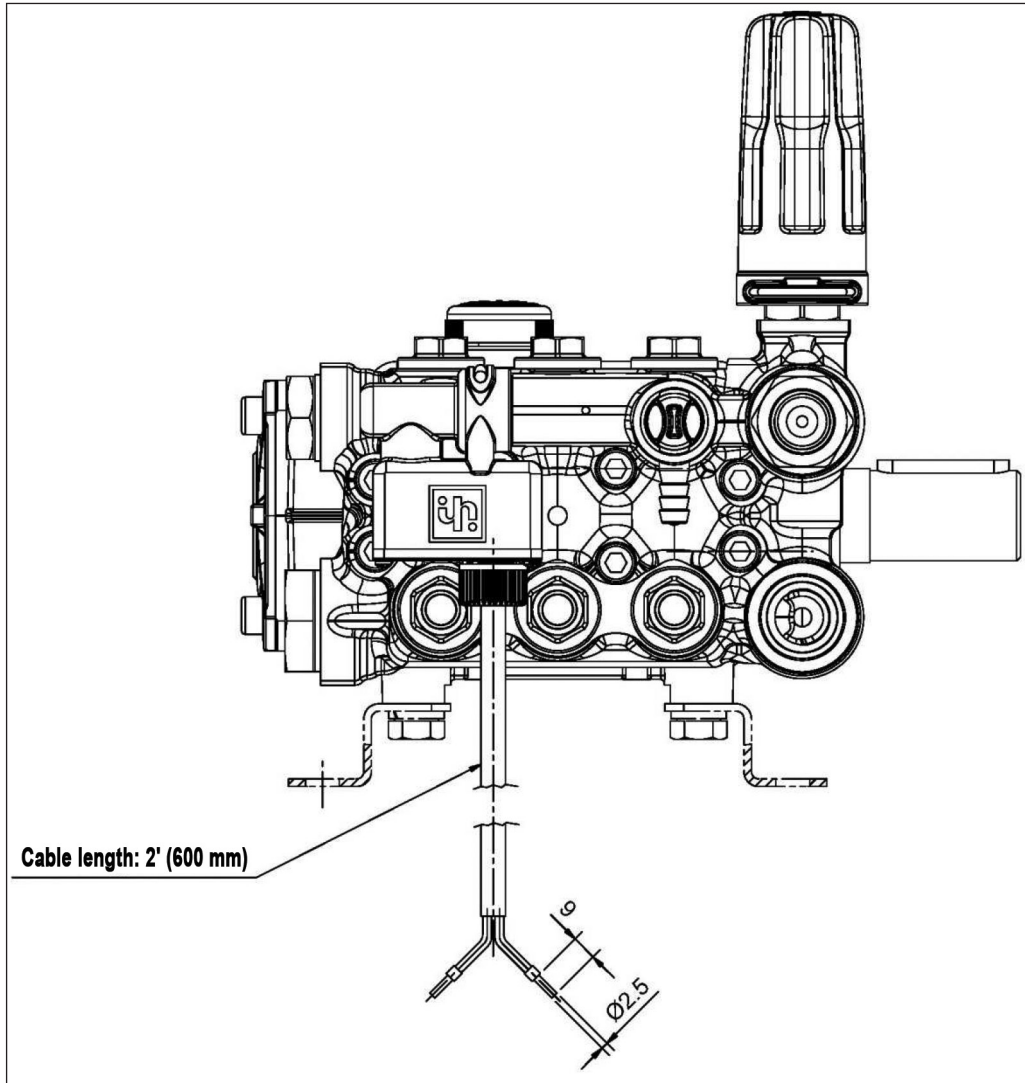
**OPERATIONAL SPECIFICATIONS**



Maximum Voltage	250 V ~
Maximum Load	16 (4) A
Protection Grade	IP55
	Gun Closed
	Gun Open

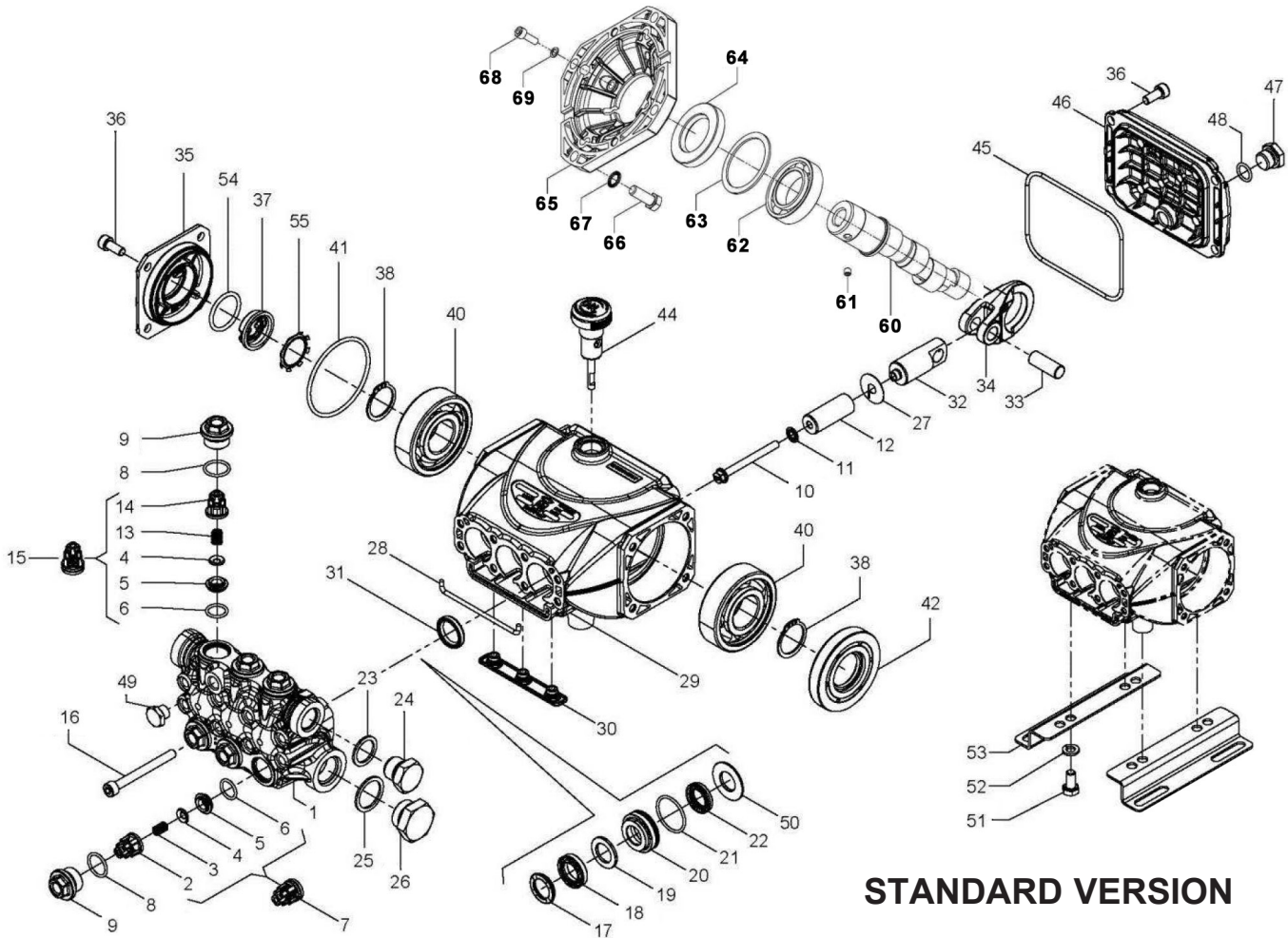

**STANDARD VERSION**

**PARTS LIST**

ITEM	PART NO.	DESCRIPTION	QTY	ITEM	PART NO.	DESCRIPTION	QTY	ITEM	PART NO.	DESCRIPTION	QTY
1.	53120015	Manifold, Ø 15	1	20.	53210170	Support Ring, Ø 15	3	45.	30391700	O-ring, Ø 88.57X2.62	1
	53120615	Manifold, Ø 13			53210470	Support Ring, Ø 13		46.	53160022	Rear Cover	1
2.	36211951	Inlet Valve Guide	3	21.	90360400	O-ring, 25.12x1.78	3	47.	98204250	Plug, 1/4"x9	1
3.	94732600	Spring, Ø 6x12	3	22.	90260800	Packing, Ø 15, LP	3	48.	701013	O-ring, Ø 10.82x1.78	1
4.	36211276	Valve, Spherical	6		90260100	Packing, Ø 13, LP		49.	98196800	Plug, 1/8"x8	1
5.	36211366	Valve Seat	6	23.	96738000	Washer, Ø17.5x23x1.5	1	50.	53210670	Support Ring, Ø15	3
6.	90367400	O-ring, Ø12.00x2	6	24.	98210050	Plug, 3/8"x13	1	51.	99303700	Screw, M8x16	4
7.	36722401	Valve Assembly	3	25.	96751400	Washer, Ø	1	52.	96701600	Washer, Ø8.4x14.4x2.0	4
8.	701016	O-ring, Ø15.6x1.78	6	26.	98218700	Plug, 1/2" BSPx10	1	53.	50200074	Pump Feet	2
9.	98213730	Valve Cap, M18x1.5x10, Ø 15	6	27.	96699000	Gasket, Ø 7.5x23x0.5	3	54.	90385900	O-ring, Ø 25.07x2.62	1
	98213740	Valve Cap, M18x1.5x10, Ø 13		28.	53210382	Gasket, Ø3x85	1	55.	90067100	Stop Ring	1
10.	99169000	Plunger Bolt, M5x55	3	29.	53010022	Crankcase	1	60.	60022265	Crankshaft, ET1504E34UTS	1
11.	96690500	Washer, Ø 5x11.5x0.4	3	30.	58210451	Drip Cover	1		60022465	Crankshaft, ET1305E34UTS	1
12.	53040009	Plunger, Ø 15x38.5	3	31.	90159300	Oil Seal, Ø 18x24x4.4	3	61.	99179000	Screw, M6x6	1
	63040609	Plunger, Ø 13x38.5		32.	53050066	Piston Guide	3	62.	91846400	Spherical Gear	1
13.	94733300	Spring, Ø 6.2x10.4	3	33.	97733800	Piston Pin, Ø 10x26.5	3	63.	60210189	Spacer	1
14.	36211151	Outlet Valve Cage Guide	3	34.	53030022	Connecting Rod	3	64.	90167500	Ring, Ø 35x62x10	1
15.	36719301	Complete Outlet Valve	3	35.	50150022	Crankcase Side Cover	1	65.	10034400	Flange	1
16.	99199000	Screw, M6x60	8	36.	99183700	Screw, M6x14	12	66.	99334500	Screw, 3/8"	4
17.	63101051	Head Ring, Ø 15	3	37.	53210851	Sight Glass	1	67.	96710400	Washer, 10.5x16.0x1	4
	44100251	Head Ring, Ø 13		38.	90063500	Ring, Seeger Ø25	2	68.	99186700	Screw, M6x18	4
18.	90261100	Packing, Ø 15, HP	3	40.	91832800	Bearing, Premium	2	69.	203510	Washer, Ø 6.4x10.0x.7	4
	90260200	Packing, Ø 13, HP		41.	90389800	O-ring, Ø 55.56x3.53	1				
19.	90508990	Anti-ext. Ring, Ø 15	3	42.	90164100	Oil Seal, Ø 25x62x10	1				
	90507650	Anti-ext. Ring, Ø 13		44.	98210800	Oil Dipstick	1				

**START-STOP MANIFOLD**

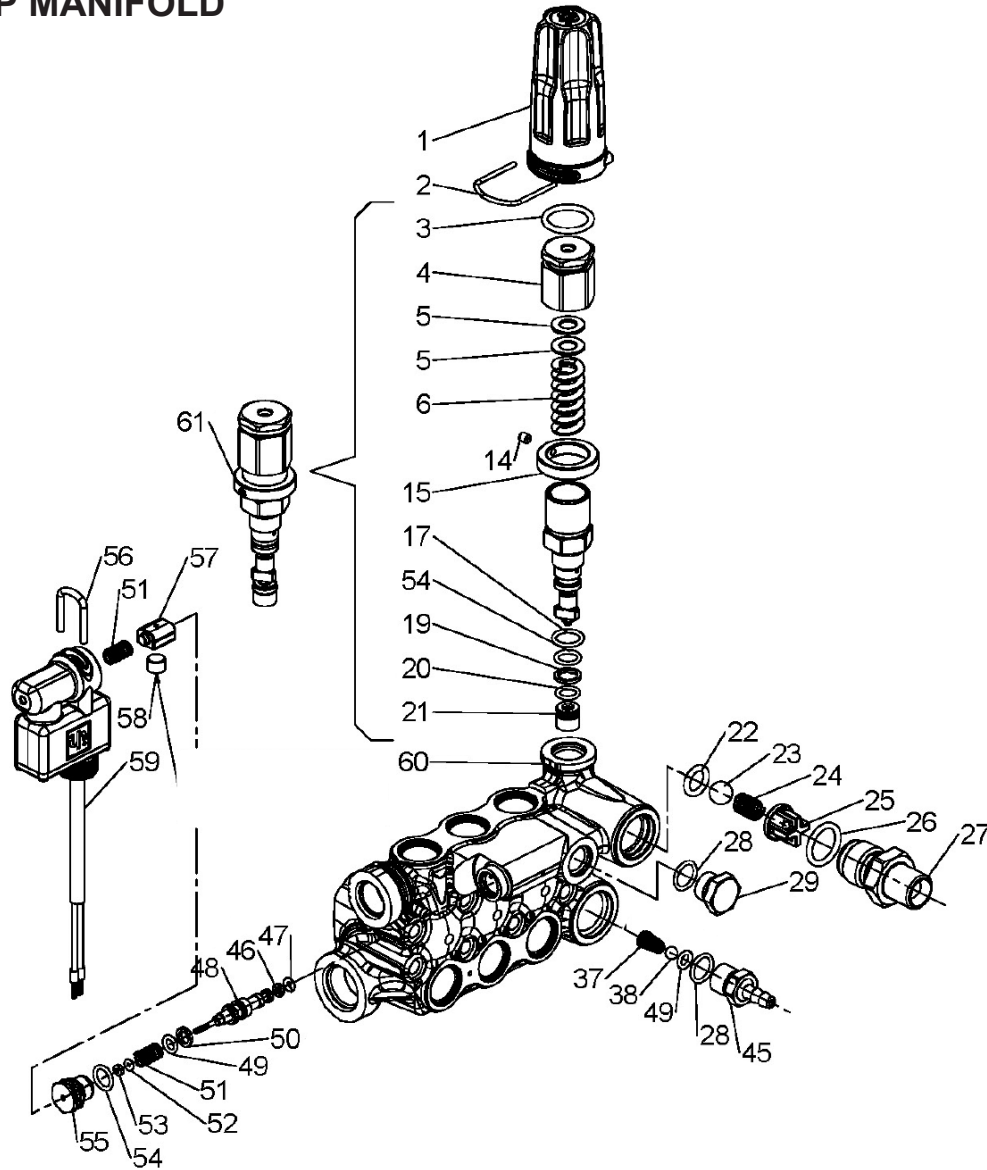

**PARTS LIST**

ITEM	PART NO.	DESCRIPTION	QTY	ITEM	PART NO.	DESCRIPTION	QTY	ITEM	PART NO.	DESCRIPTION	QTY
1.	36351751	Regulating Knob, Black	1	25.	36310451	Valve Guide	1	47.	90500400	Anti-extrusion Ring	1
2.	10084666	Clip, Regulating Knob	1	26.	90383900	O-ring, Ø 15.88x2.62	1	48.	36351466	Plunger, Total Stop	1
3.	90384500	O-ring, Ø 18.72x2.62	1	27.	36347970	Nipple, 3/8" BSP-M	1	49.	90357300	O-ring, Ø 5.28x1.78	1
4.	36348170	Pressure Regulator	1		36349070	Nipple, 3/8" NPT-M (opt.)		50.	90502100	Anti-extrusion Ring	1
5.	36348651	Washer	2		36348970	Nipple, 3/8" BSP-F (opt.)		51.	94733350	Spring, Ø 6.3x16.1	2
6.	94739500	Spring, Ø 11.3x34.5	1		36348870	Nipple, 3/8" M22x1.5 (opt.)		52.	90356200	O-ring, Ø 1.78x1.78	1
14.	99126700	Screw, M04x05	1		36348770	Nipple, 3/8" NPT-F (opt.)		53.	90500000	Anti-extrusion Ring	1
15.	36347770	Maximum Pressure Ring	1	28.	90358500	O-ring, Ø 10.82x1.78	1	54.	90358100	O-ring, Ø 8.73x1.78	2
17.	90358700	O-ring, Ø 11.11x1.78	1	29.	98204100	Plug, G 1/4"x9	1	55.	36350470	Plunger Guide, Total Stop	1
18.	90358100	O-ring, Ø 8.73x1.78	2	36.	10079566	Injector Nozzle	1	56.	10061166	Stop Clip	1
19.	90503800	Anti-extrusion Ring	1	37.	94821700	Spring, Conical	1	57.	36024051	Magnet Slide	1
20.	90357800	O-ring, Ø 7.66x1.78	1	38.	97478200	Ball, Ø 7/32"	1	58.	36351500	Magnet	1
21.	36348366	Valve Seat	1	43.	90359100	O-ring, Ø14.0x1.78	2	59.	36601301	Assembly, Total Stop	1
22.	90382300	O-ring, Ø09.92x2.62	1	45.	36349270	Hose Barb	1	60.	53121315	Manifold, Ø 15, L	1
23.	97483800	Poppet, Ø 13/32"	1		36023551	Hose Barb, Swivel	1	61.	36605401	Valve with Seat	1
24.	94735500	Spring, Ø 8.5x12.0	1	46.	90356600	O-ring, Ø 2.90x1.78	1				

**REPAIR KITS**

**TORQUE SPECS\***

**STANDARD**

KIT NO.	K309	K311	Ø 13			Ø 15		
			K333	K318	K319	K310	K312	K313
ITEM NO'S INCLUDED IN KIT	2, 3, 4, 5, 6, 13, 14, (7), (15)	31	8, 9	17, 18, 19, 21, 22	17, 18, 19, 20, 21, 22, 50	8, 9	17, 18, 19, 21, 22	17, 18, 19, 20, 21, 22, 50
NUMBER OF PIECES	6	3	6	3	1	6	3	1

KIT NO.	K278	K280
ITEM NO'S INCLUDED IN KIT	22, 23, 24, 25, 26, 61	28, 37, 38, 45, 49
NUMBER OF PIECES	1	1

**STANDARD**

Position	Ft.-Lbs.	Nm.
9	44.3	60
10	4.4	6
16	8.9	12
26	30	40
26	30	40
36	7.4	10
47	7.4	10
49	9.6	13
51	14.8	20
68	7.4	10

**START-STOP**

Position	Ft.-Lbs.	Nm.
27	32.5	44
29	14.8	20
45	14.8	20
55	5.2	7

\*\*Use Loctite 542 Red

\*Decrease torque by 20% if threads are lubricated.

**DIMENSIONS**

