

**GENERAL PUMP** *A member of the Interpump Group*

# EZ Series 44

## Triples Plunger Pump

**FEATURES**

- Standard SAE J609 gasoline mounting flange for up to 13 hp engines
- Forged brass manifold with an exclusive lifetime warranty and 3:1 hydrostatic rating
- Die-cast, anodized aluminum oil-bath crankcase
- Innovative one-piece plunger design to eliminate water entering crankcase
- Premium roller bearing
- 5% reduction in crankcase load compared to standard 3,000 PSI, 15 mm pumps
- Unitized stainless steel inlet and discharge valves
- Available in "L" left-handed versions

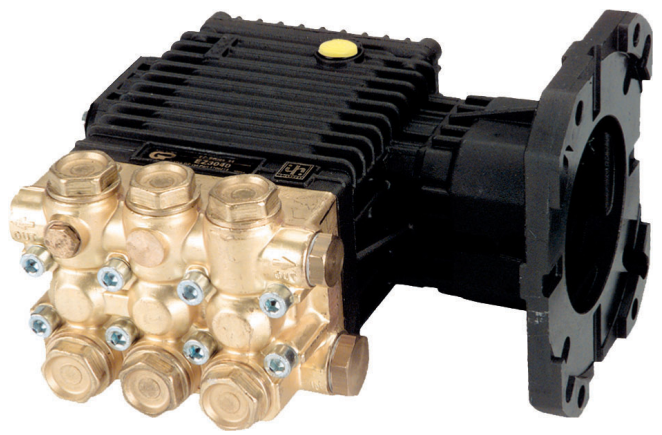

**SPECIFICATIONS**

Pump Model	EZ4040G	EZ4035G34	EZ4030G34
Maximum Volume	4.0 GPM	3.5 GPM	3.0 GPM
Maximum Discharge Pressure	4200 PSI	4000 PSI	
Maximum Pump Speed	3400 RPM		
Maximum Inlet Pressure	125 PSI		
Maximum Inlet Vacuum	3 ft. water (2.6 in. Hg)		
Plunger Bore	.512 in. / 13 mm		
Plunger Stroke	.512 in. / 13 mm	.433 in. / 11 mm	.374 in. / 9.5 mm
Crankcase Oil Capacity	14.0 oz.		
Maximum Fluid Temperature	165° F		
Inlet Port Thread	1/2-14 BSPP-F		
Discharge Port Thread	3/8-19 BSPP-F		
Shaft Diameter	1.0 in. / 25.4 mm		
Weight	20 lbs.		
Dimensions	8.8" x 9.7" x 6.5"		

**DIMENSIONAL DRAWING**

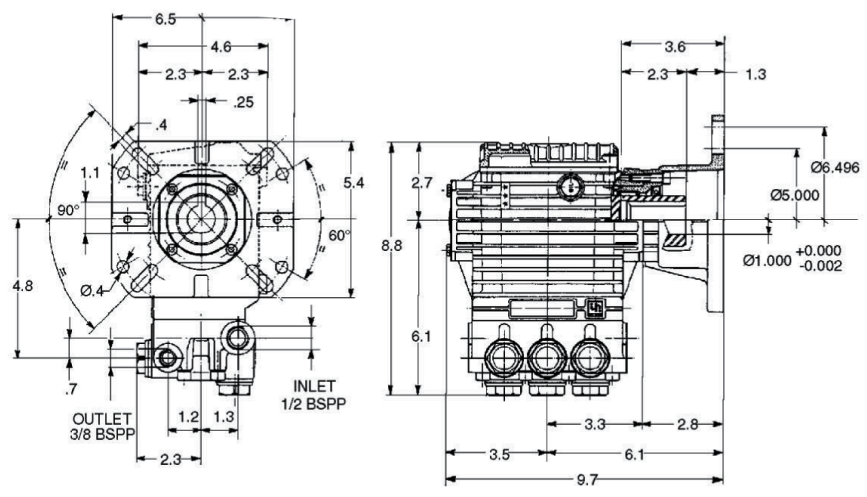

General Pump is a member of the Interpump Group



Ref 300071 Rev. L  
12-19



# EZ Series 44 - Triplex

**GENERAL PUMP** *A member of the Interpump Group*

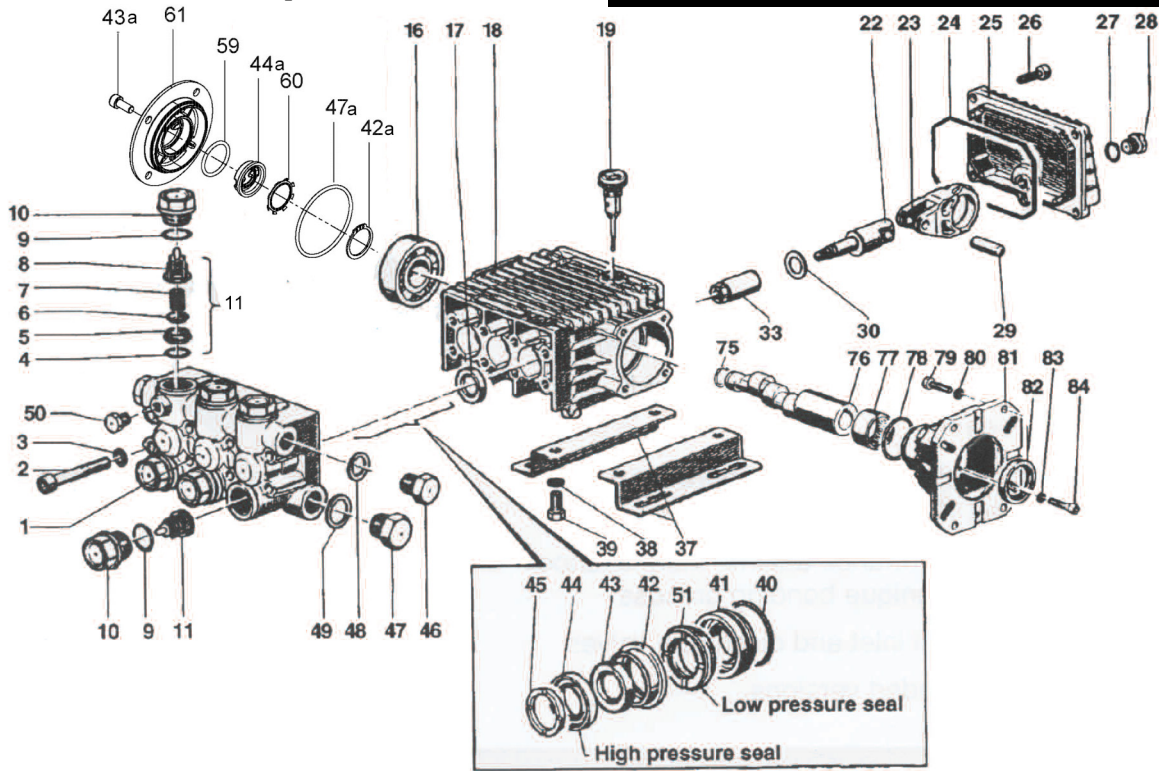

## PARTS LIST

ITEM	PART NO.	DESCRIPTION	KIT NO.	QTY.	ITEM	PART NO.	DESCRIPTION	KIT NO.	QTY.	ITEM	PART NO.	DESCRIPTION	KIT NO.	QTY.
1.	44120641	Manifold		1	26.	99183700	Screw		5	47a.	90389800	O-ring Ø 56.82x2.62		1
2.	99317500	Screw		8	27.	701013	O-ring		1	48.	96738000	Washer		1
3.	96701400	Washer		8	28.	98204100	Cap Screw		1	49.	96751400	Washer		1
4.	701115	O-ring	123	6	29.	97734000	Pinr		3	50.	98196600	Cap Screw		1
5.	36200366	Valve Seat	123	6	30.	96696700	Washer		3	51.	90260300	Seal, Low Pressure	153,156	1
6.	36711501	Valve	123	6	33.	44040266	Plunger, 13 mm		3	59.	90385900	O-ring Ø 25.07x2.62		1
7.	94737600	Spring	123	6	37.	50200074	Rail		2	60.	90067100	Stop Ring		1
8.	36202551	Valve Cage	123	6	38.	96701600	Washer		4	61.	58150122	Side Cover		1
9.	701002	O-ring	124	6	39.	99303700	Nut		4	75.	90063500	Retaining Ring		1
10.	98222600	Cap Screw	124	6	40.	90361200	O-ring	156	3	76.	44022165	Crankshaft (EZ4040G)		1
11.	36711501	Valve Assembly	123	6	41.	44080370	Packing Retainer	156	3		44021265	Crankshaft (EZ4035G34)		1
16.	91832800	Ball Bearing		1	42.	44216270	Intermediate Ring	156	3		44020965	Crankshaft (EZ4030G34)		1
17.	90161400	Oil Seal	23	3	42a.	90063500	Stop Ring Ø 25		1	77.	91856800	Roller Bearing		1
18.	44010022	Crankcase		1	43.	90507600	Packing	153,156	3	78.	90409700	O-ring		1
19.	98210300	Oil Dip Stick		1	43a.	99183700	Screw M6x14		4	79.	99275500	Screw, 5/16 x 1		4
22.	44050166	Piston Guide		3	44.	90260200	Packing	153,156	3		99334500	Screw, 3/8 x 1		4
23.	44030022	Connecting Rod		3	44a.*	53210851	Oil Level Indicator		1	80.	203476	Washer, 8 mm		4
24.	90392000	O-ring		1	45.	44100251	Head Ring	156	3		96710400	Washer, 10 mm		4
25.	44160022	Rear Cover		1	46.	98210000	Cap Screw		1	81.	10051822	Gas Flange		1
26.	99183700	Screw		5	47.	98217600	Cap Screw		1	82.	90169000	Oil Seal		1
27.	701013	O-ring		1	47a.	90389800	O-ring Ø 56.82x2.62		1	83.	203510	Washer		4
25.	44160022	Rear Cover		1	48.	96738000	Washer		1	84.	99191200	Screw		4

\* 53150001 Oil Level Indicator Assembled W/O Screws and O-ring

## REPAIR KITS

KIT NO.	K23	K123	K124	K153	K156
ITEM NO's INCLUDED IN KIT	17	4, 5, 6, 7, 8, (11)	9, 10	43, 44, 51	40, 41, 42, 43, 44, 45 51
NUMBER OF ASSEMBLIES IN KIT	3	6	6	3	1
NUMBER OF CYLINDERS KIT WILL SERVICE	3	3	3	3	1

## TORQUE SPECS\*

Pos.	Ft/lb	N-M
2	14.7	20
10	95.9	130
12	7.3	10
26	7.3	10
28	14.7	20
46	29.4	40
47	29.4	40
50	9.6	13
79	14.7	20
84	7.3	10

\* Decrease torque by 20% if threads are lubricated

**GENERAL PUMP** 1174 Northland Drive • Mendota Heights, MN 55120  
Phone: 651.686.2199 • Fax: 800.535.1745 • e-mail: sales@gpcompanies.com • www.generalpump.com

Ref 300071 Rev. L  
12-19

