

GENERAL PUMP *A member of the Interpump Group*

PLSRZ87SS

Stainless Steel Flow Sensitive Unloader Valve

FEATURES

- Near total zero setting of the outlet pressure at gun closure increases safety
- Reduced pressure loss
- Makes for easier gun operation
- Extremely reliable
- Easy maintenance

SPECIFICATIONS

Part Number PLSRZ87SS
 Max. Volume 2.3 to 16.0 GPM
 Max. Pressure 8700 PSI
 Min. Pressure 1015 PSI
 Max Temperature 140° F
 Note: The valve has been designed for continuous use at a water temperature of 140° F. It can operate for short periods at a maximum temperature of 195° F.

Port Sizes: Inlet 1/2" BSP-F
 Outlet 1/2" BSP-F
 Bypass 1/2" BSP-F

Overall Dimensions 9.9" x 4.47" x 2.1"
 Weight 4.7 lbs.



General Pump recommends using a safety relief device in conjunction with this unloader valve when installed on a positive displacement pump. General Pump is not liable and assumes no responsibility when used in a customer's high pressure system.

PARTS LIST

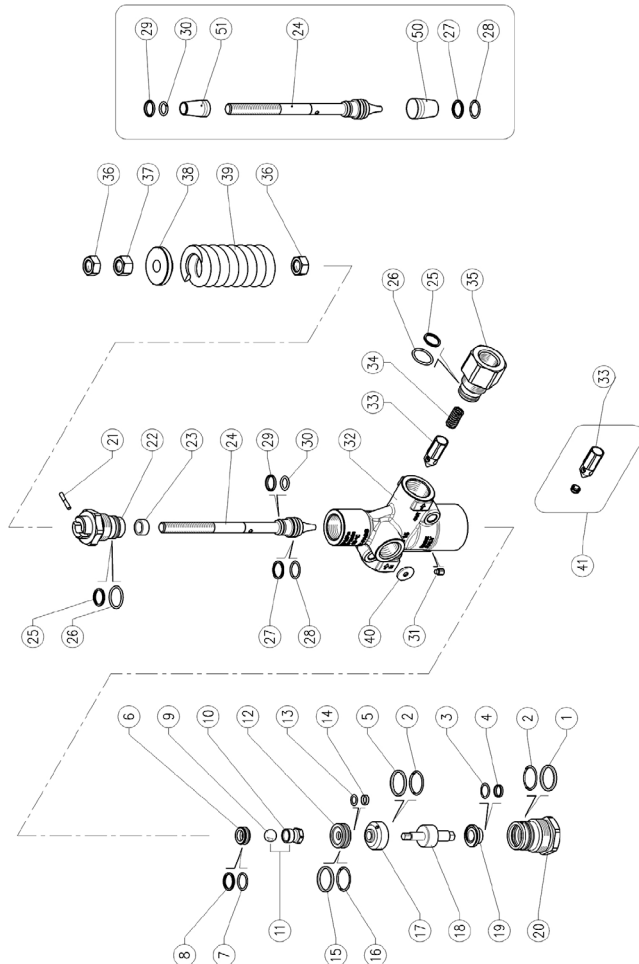

No.	Part No.	Description	Qty
1*	Y10409800	Back-up Ring, 23.2 x 26 x 1.2 mm	1
2*	Y10307260	O-ring, 1.78 x 21.95 mm	2
3*	Y10305801	O-ring, 1.78 x 10.82	1
4*	Y10405500	Back-up Ring, 9.2 x 11.2 x 2 mm	1
5*	Y10405900	Back-up Ring, 20 x 22 x mm	1
6*	Y60261551	Seat, SST, 8.5 mm	1
7*	Y10306001	O-ring, 1.78 x 12.42 mm	1
8*	Y10401300	Back-up Ring, 16 x 13.2 x 1.2 mm	1
11*	Y60261621	Shutter Pin, M6, SST & Ball, 13/32"	1
12	Y60260651	Piston Ring, SST, 7 mm	1
13*	Y10305600	O-ring, 1.78 x 8.74 mm	1
14*	Y10400792	Back-up Ring, 7 x 9 x 2	1
15*	Y10404100	Back-up Ring, 19.3 x 22 x 1.2 mm	1
16*	Y10307002	O-ring, 1.78 x 18.77	1
17	Y60260951	Spacer Ring, 7 mm	1
18	Y60260751	Pin, SST	1
19	Y60261051	Piston Ring, 9.2 mm	1
20	Y60260451	Plug, Lower, SST	1
21	Y60261151	Pin, 3.1 x 18 mm, SST	1
22	Y60260351	piston Holder, SST	1
23*	Y26104684	Bushing, 10 x 14 x 7 mm	1
24	Y60260251	Piston Valve, SST	1
25*	Y10409900	Back-up Ring, 17.2 x 20 x 1.2 mm	2
26*	Y10306801	O-ring, 1.78 x 17.17 mm	2
27*	Y10416100	Back-up Ring, 18 mm	1
28*	Y10306000	O-ring, 1.78 x 12.42	1
29*	Y10416200	Back-up Ring, 14.2 mm	1
30*	Y10305700	O-ring, 1.78 x 9.25 mm	1
31	Y16220300	Set Screw, M6 x 10 mm, SST	1
32	Y60260555	Housing, SST	1
33	Y60260851	Shutter, SST	1
34	Y60260151	Spring, SST, 1.3 x 8.5 x 24 mm	1
35	Y60261257	Shutter Coupling, SST	1
36	Y11462900	Hex Nut, M10	2
37	Y11462000	Hex Nut, M10	1
38	Y60261451	Washer, Spring Holder, SST	1
39	Y60043461	Spring, 8.5 x 38 x 80 mm, Black	1
40	Y60262931	Washer, 2.5 mm, Brass (optional)	1
	Y60262331	Washer, 3.0 mm, Brass (optional)	1
	Y60262431	Wahser, 4.5 mm, Brass (optional)	1
50	Y10440700	Seal Frame, (optional)	1
51	Y10440800	Seal Frame, (optional)	1
*	Y60261824	Repair Kit	1

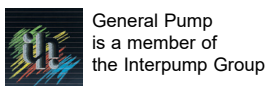

DIMENSIONS

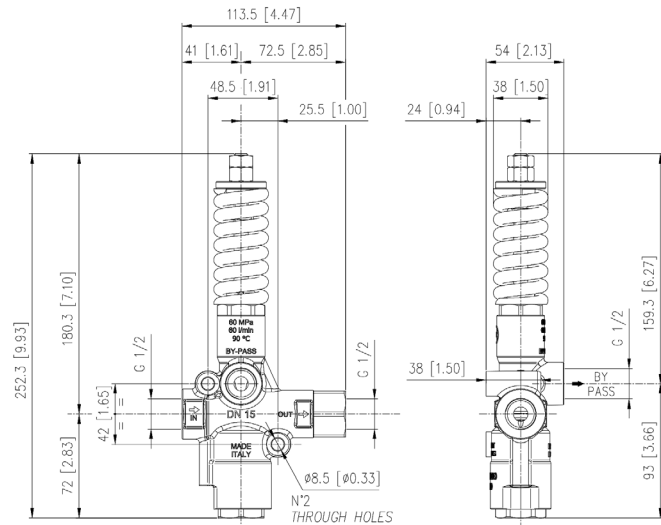

SELECTION AND OPERATION

SELECTION

This product is intended to be incorporated on a finished machine. This product is to be used with clean fresh water, for use involving different or corrosive liquids, contact the GP Customer Service Department. Appropriate filtration should be installed when using impure liquids. Choose the valve appropriate to the working data of the pump (permissible pressure, flow and rated temperature of the system). The pressure of the pump must not exceed the maximum pressure of the valve.

ATTENTION: The PLSRZ87SS valve is sensitive to water flow; at gun opening the system goes into pressure, at gun closing (flow interruption) the system works at low pressure. For this reason the PLSRZ87SS must not be installed on systems using constant-weep guns. Instead it can be used on systems using guns which weep at low pressure. In this case it is necessary to create in the bypass line a pressure higher than the pressure at which the gun begins weeping.

OPERATION

The valve regulates the maximum pressure of the system by varying the flow discharged by the bypass. The adjustment is made by altering, by means of a piston, the position of a sphere which partially closes the bypass opening. The valve is sensitive to water flow. At gun opening, the water flows through the valve which maintains the system in pressure until the gun closes, the interruption of the flow provokes the complete aperture of the bypass which allows to discharge the flow at low pressure. At gun closure, the special mechanism of zero setting, which does not include a check valve, keeps in connection the delivery line and the bypass line, in that way permitting to lower the pressure all around the system and not only in the source line of the valve.

INSTALLATION

This valve, on a system that produces hot water, must be fitted upstream from the source of heat. On a system that generates hot water, it is advisable to use accessories that limit the accidental increase of fluid temperature. **Always install a safety valve.** We recommend the use of a nozzle with flow rate which allows a regular discharge from the valve bypass of at least 5% of the flow supplied by the pump. In order to achieve a constant pressure and easy adjustment. If the nozzle wears out, the pressure decreases. To reset pressure back to working level, it is necessary to replace the worn nozzle. When a new nozzle is fitted, resetting of the system to its original working pressure is required.

DISCHARGE SYSTEM AND WATER ADDUCTION

The PLSRZ87SS bypass flow is also discharged. In certain conditions, depending on installation and in particular:

- through feeding from tank
- with long delivery lines or strong difference in level
- with low flow and small flow factor nozzles

It could occur that at gun opening, a delay in the reset of the working pressure is revealed or a pulsation of the valve. To avoid such occurrences, it is necessary to always guarantee a pressure of at least 43-72 PSI in the bypass line. This pressure can be obtained by throttling the bypass line in one of the following ways:

- fitting in the bypass channel a 3/8" tube instead of 1/2"
- fitting in the bypass channel a rigid tube of a sufficiently small diameter
- inserting in the bypass channel a connector with an adequate orifice diameter
- inserting in the bypass connection (picture 1) a washer with an adequate diameter (available on request; see chart below)

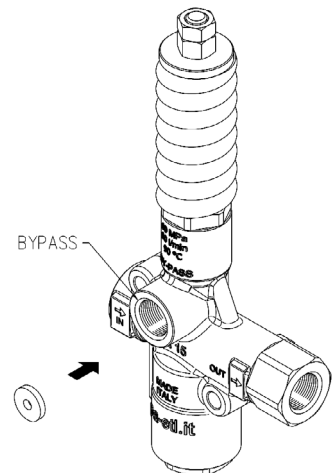

Picture 1

Available Washers on Request			
Flow (GPM)	Ø Orifice (mm)	Connector Thread	Part Number
Special	2.5	BSP	Y60262931
2.5 - 4.0	3	BSP	Y60262331
4.0 - 8.0	4.5	BSP	Y60262431

INSTALLATION (continued)

In the case of feeding from a tank where also the bypass flow is discharged, it would be advisable to fit in the feed line of the machine a low pressure pump that guarantees a feed pressure of 43-72 PSI (see paragraph "Examples of Installation", Picture 4). It is advisable that the tank be provided with deflectors (baffles) to reduce eventual turbulence and air bubbles, generated by the intake of the bypass flow, which could be harmful for the pump.

In the case of direct pump recycle of the bypass flow and if bypass conditions are foreseen frequently or for a long period of time, it is advisable to fit a thermal valve (PTP) in order to avoid dangerous overheating of recycled water.

EXAMPLES OF INSTALLATION

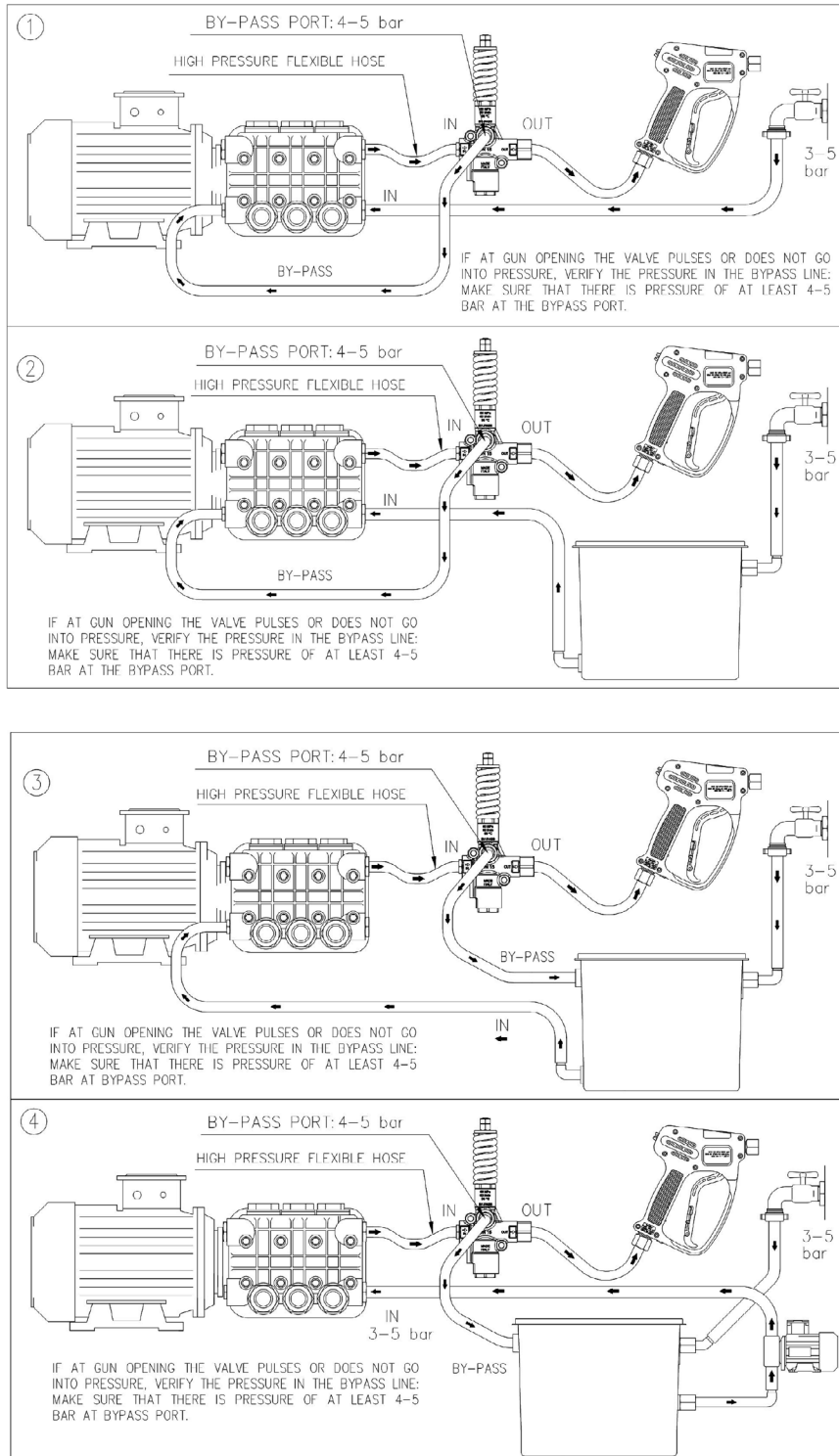

PRESSURE ADJUSTMENT/SETTING

The desired working pressure must be adjusted while the system is in operation and the gun is opened. Alter the pressure by screwing or unscrewing the adjustment knob. The operation is easier if the correct nozzle has been chosen (see paragraph "Installation". Pressure is increased by rotating the adjustment knob. In case pressure does not increase despite turning of the knob, **do not force**, but check that the nozzle flow rate/pressure ratio is correct.

MAINTENANCE

STANDARD: every 400 working hours, check and lubricate the seals with water resistant grease.

SPECIAL: every 800 working hours, check the wear of the seals and internal parts and, if necessary, replace with original GP parts taking care, during installation, to lubricate with water resistant grease.

The manufacturer is not to be considered responsible for damage as a result from incorrect fitting and maintenance.

TROUBLESHOOTING

PROBLEMS	PROBABLE CAUSES	SOLUTIONS
At gun opening, too much time is required to reach working pressure.	Delivery tube very long or level difference Nozzle with very small flow factor (<04) Pump feed from tank	Throttle bypass line
At gun opening, the valve pulses	Delivery tube very long or level difference Nozzle with very small flow factor (<04) Pump feed from tank	Throttle bypass line
At gun closure, the valve pulses (rearm)	Gun leaks Leaks from delivery line	Repair the gun to eliminate leakage Eliminate the leakage
At gun closure, the valve does not lower the pressure on the delivery line	Orifice of the shutter blocked (position 4 of exploded view)	Clean and eliminate obstruction
Valve does not reach maximum pressure	Worn nozzle Seat damaged or worn Presence of matter between seat and shutter	Replace Replace Clean seat
Valve does not go into pressure	O-rings of SST piston (positions 21-24 and 27-28 of the exploded view) damaged	Replace