

Triplex Plunger Pump, High-temp Seals

FEATURES

- Features patented "high tech" packings:
 - dynamic low-pressure seal retainer
 - superior low-pressure seal
 - innovative intermediate ring
 - superior high-pressure seal
- Nickel-plated manifold
- New plunger guide bushing (patent pending)
- Solid ceramic plungers with dual guide system
- New dual diameter plunger guide
- New optimized outlet valves
- New dual lip oil seal



SPECIFICATIONS

Pump Model	EPHT1810S	EPHT1812S	EPHT1813S
Maximum Volume	2.91 GPM	3.96 GPM	3.43 GPM
Maximum Discharge Pressure	2,465 PSI		
Horsepower	5.6 EBHP	6.6 EBHP	5.7 EBHP
Maximum Pump Speed	1450 RPM	1750 RPM	1450 RPM
Inlet Pressures	Flooded to 70 PSI		
Plunger Bore (in / mm)	.708 in./18 mm		
Plunger Stroke (in / mm)	.394 in./10 mm	.472 in./12 mm	.512 in./13 mm
Oil Capacity	14 oz.		
Maximum Fluid Temperature	185° F		
Inlet Port Thread	1/2"-14 BSP-F		
Discharge Port Thread	3/8"-19 BSP-F		
Shaft Diameter	.945 in./24 mm		
Weight	18.0 lbs.		
Dimensions - Nominal	9.5" x 8.38" x 5.1"		

Available in left hand version, add L to end of part number

TRIPLEX

TRIPLEX

Instructions and Recommendations for the Installation of *EPHT Series Pump*

Maximum temperature of the water through the pump is 185° F (85° C).

In order to obtain maximum performance in terms of duration of seals and valves, it is necessary to respect a few simple rules, as follows:

- 1) **In order to avoid damage caused by cavitation, the pump must be pressure fed.**

Note: Contact General Pump's technical sales department for guidance when operating the pump outside of the related inlet specs.

- 2) **The plumbing which feeds the pump must be of a diameter at least equal to the inlet port.**

Also, follow the suggestions below:

- a) Make the plumbing as short and straight as possible, preferably in an upward direction to facilitate the expulsion of eventual air bubbles naturally if compatible with the requirements of the system.
- b) It is always useful to put a filter at the inlet with capacity of 4 to 5 times the flow of the pump, for example for a 4 gpm (15 l/min) pump, put a filter from 16 to 20 gpm (60-75 l/min). The mesh size suitable for this application is 0.016" (.4 mm).
- c) It is extremely important to put a pressure switch on the suction port of the pump, and in any case downstream from the filter, so that it can stop the pump should the feed pressure drop by 20% due to the filter clogging or failure of the feed pump, etc.

- 3) **Change of oil**

We recommend the **first oil change after the first 50 hours**, with the **pump stopped** and the **oil still warm**.

This change is not recommended because the oil has lost its properties, but rather to eliminate the impurities that have gotten into the oil during the running-in phase. If these impurities are not removed, but are allowed to remain in the oil, they *may cause premature wear* to the moving parts and the oil seals. **After this initial change, the oil can then be changed every three months or 300 hours of operation thereafter.**

Please note: If the pump works in conditions with high humidity and with sharp temperature changes, it is possible that condensation will appear inside the crankcase, which mixing with the oil can change its properties. This is easy to see because the oil changes to a white, milky color.

If the pump does not have excessive water leaking from the packings, and the oil becomes milky, the oil has to be changed more frequently. The percentage of water in the oil must not exceed 20%.

Use oil per the following chart:

CHART OF COMPATIBLE OILS	
General Pump	Series 100
BP	VISCO 2000
CASTROL	CWX
MOBIL	SUPER
SHELL	HELIX SUPER
TOTAL	QUARTZ 4000-5000

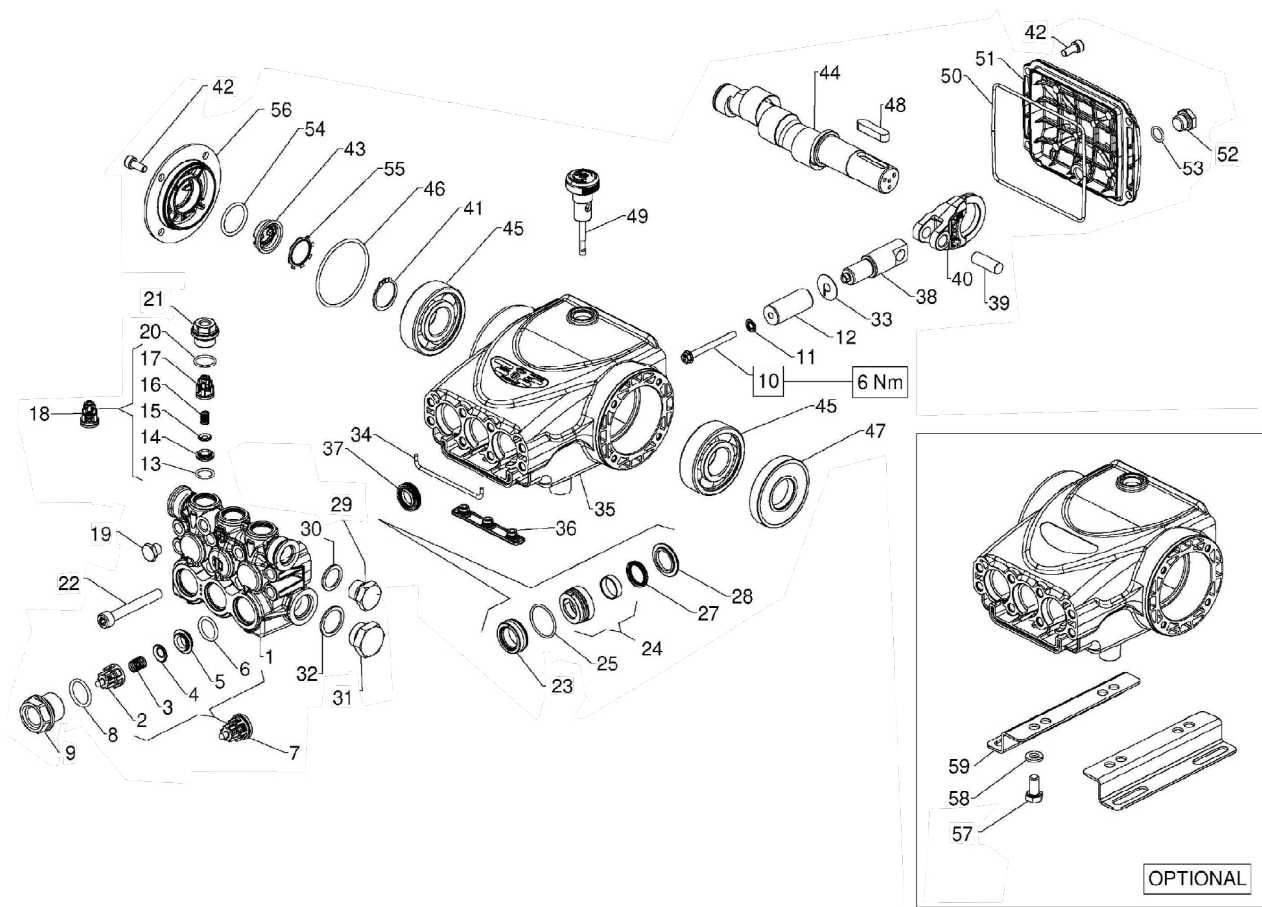

PARTS LIST

ITEM	PART NO.	DESCRIPTION	QTY	ITEM	PART NO.	DESCRIPTION	QTY	ITEM	PART NO.	DESCRIPTION	QTY
1.	58120741	Manifold, Ø 18	1	23.	90221000	Seal, HP, HT, Ø 18,	3	44.	63021235	Crankshaft, 10mm	1
2.	36202551	Valve Cage	3	24.	58606401	Int. Ring Packing, Ø 18	3		63021635	Crankshaft, 12mm	1
3.	94737600	Spring, Ø 9.4x14.8	3	25.	90360650	O-Ring, Ø 26.7x1.78, HNRB	3		63021835	Crankshaft, 13mm	1
4.	36200176	Valve	3	27.	90220000	Seal, LP, HT Ø 18	3				
5.	36200366	Valve Seat	3	28.	58211270	Support Ring, Ø 18	3	45.	91833100	Bearing, Premium	2
6.	701115	O-ring, Ø17.13x2.62	3	29.	98209900	Plug, G3/8"x13	1	46.	90389800	O-ring, Ø 56.82x2.62	1
7.	36726201	Valve Assembly	3	30.	96738000	Gasket, 17.5x23x1.5	1	47.	90164100	Oil Seal, Ø 25x62x10	1
8.	90384750	O-ring, Ø20.24x2.62	3	31.	98217900	Plug, 1/2" BSPx10	1	48.	91489200	Oil Dipstick	1
9.	98222500	Valve Cap, M24x1.5x16.7	3	32.	96751400	Gasket, Ø 21.5x27x1.5	1	49.	98210500	O-ring, Ø 113.97x2.62	1
10.	99169000	Plunger Bolt, M5x55	3	33.	96699000	Washer, Ø 7.5x15x0.5	3	50.	90392550	O-ring, Ø 113.97x2.62	1
11.	96690500	Washer, Ø 5x11.5x0.4	3	34.	58210582	Gasket, Ø 3x94	1	51.	58160022	Rear Cover	1
12.	58040209	Plunger, Ø 18x42	3	35.	58010022	Crankcase	1	52.	98204250	Plug, 1/4"x9	1
13.	90367450	O-ring, Ø 12.42x1.78	3	36.	58210451	Drip Cover	1	53.	701013	O-ring, Ø 10.82x1.78	1
14.	36211366	Outlet Valve Seat	3	37.	90156550	Oil Seal, Ø 15x24x5.7	3	54.	90385900	O-ring, Ø 25.07x2.62	1
15.	36211276	Outlet Valve Poppet	3	38.	58050066	Piston Guide	3	55.	90067100	Stop Ring	1
16.	94733300	Spring, Ø 6.2x10.4	3	39.	97734000	Piston Pin, Ø 10x29.5	3	56.	58150122	Side Cover	1
17.	36211151	Outlet Valve Cage Guide	3	40.	58030022	Connecting Rod	3	57.	99303700	Screw, M8x16	4
18.	36729801	Complete Outlet Valve	3	41.	90063500	Stop Ring Ø 25	1	58.	96701600	Washer, Ø 8.4	4
19.	98196700	Plug	3	42.	99183700	Screw, M6x14	8	59.	50200074	Pump Foot	2
20.	701016	O-ring, Ø 15.6x1.78	3	43.	53210851	Oil Level Indicator	1				
21.	98213750	Outlet Valve Cap, M18x1.5x10	3								
22.	99317500	Screw, M8x60	8								

REPAIR KITS

KIT NO.	K415	K418	K271	K416	K417
ITEM NO'S INCLUDED IN KIT	2, 3, 4, 5, 6, 13, 14, 15, 16, 17, (7), (18)	8, 9, 20, 21	37	23, 24, 25, 27	23, 24, 25, 27, 28
NUMBER OF ASSY'S IN KIT	6	6	3	3	1
NO. OF CYLINDERS KIT SERVICES	3	3	3	3	1

TORQUE SPECS*

Position	Ft.-Lbs.	Nm.
9	96	130
10	4.5	6
19**	9.6	13
22	14.8	20
29**	30	40
31	30	40
42	7.4	10
52	14.8	20

*Decrease torque by 20% if threads are lubricated.
 **Use Loctite 542 Red
 † Note: Seal tool included

DIMENSIONS

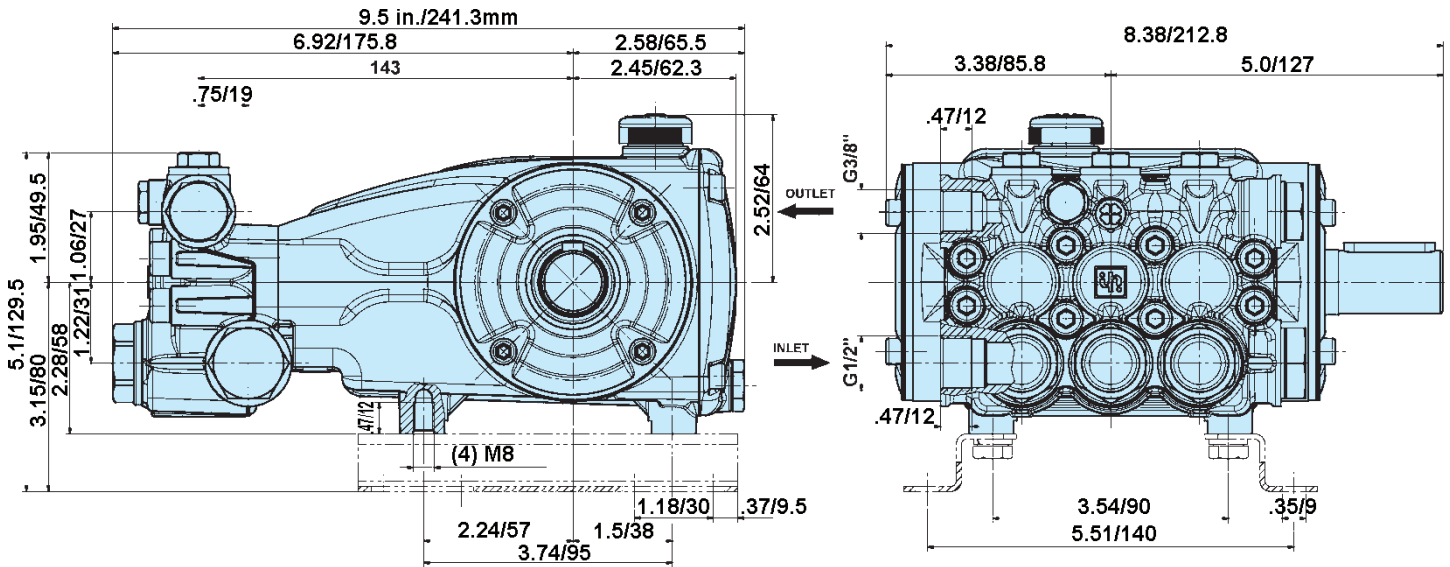

WARNING: High Pressure Systems require a primary pressure regulating device (i.e. regulator, unloader) and a secondary pressure relief device (i.e. pop-off valve, relief valve). Failure to install such relief devices properly could result in personal injury or damage to pump or property. GP does not assume any liability or responsibility for the operation of the user's high pressure system.

 **WARNING:** This product can expose you to chemicals including lead, which is known to the state of California to cause cancer and birth defects or other reproductive harm. For more information, go to www.P65Warnings.ca.gov

