

GENERAL PUMP A member of the Interpump Group

Chemical Injector

Forged Chemical Injector - Stainless Steel

FEATURES

- Ideal for 2-step applications
- Forged 304 stainless steel for superior strength and flow
- A cost effective solution to your chemical application needs



SPECIFICATIONS

Assembly Part No.	101169	101170	101171	101172	101173
Forged Body	2454007	2454007	2454007	2454006	2454006
Recommended Nozzle	520116	520066	520065	520127	520373
Nozzle Orifice	1.8 mm	2.1 mm	2.2 mm	2.3 mm	3.2 mm
Style	FIXED				
Operating Pressure	5500 PSI				
Flow Range	2 - 3 GPM	2 - 4 GPM	3 - 5 GPM	5 - 8 GPM	8 - 10 GPM
Max. Temperature	195° F				
Port Sizes	Inlet :		3/8" NPT-M		
	Discharge :		3/8" NPT-M		
	Chemical Port :		1/4" NPT-F		
Weight	.4 lbs.				
Materials	304 Stainless Steel				

TYPICAL CONFIGURATION

No.	Part No.	Description	QTY
1	YCV14FSSLC	Check valve, 1/4" NPT-F, SS	1
2	See Table Above	Housing, Injector, SS	1
3	See Table Above	Nozzle, Injector, SS	1

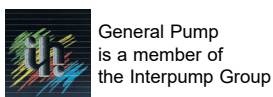
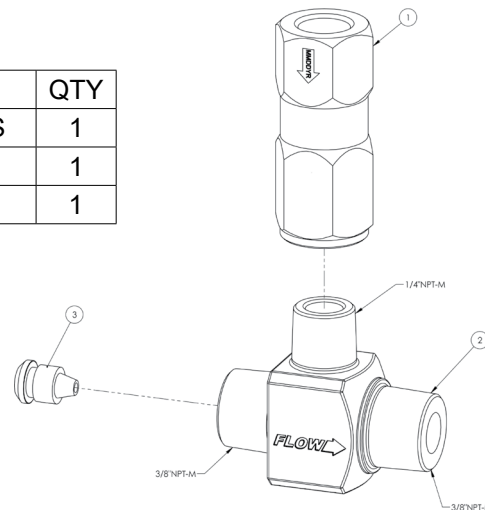

Ref 301139 Rev. B
10-23



Chemical Injector

Color-coded Chemical Injector - Stainless Steel

DIMENSIONS

in. / [mm]

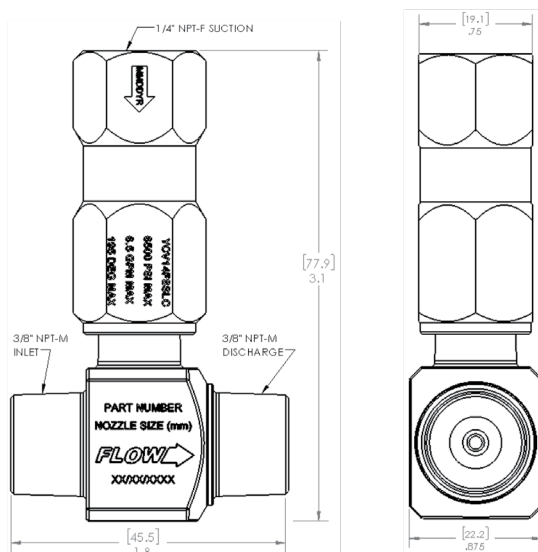

INSTALLATION

This product is to be used with clean, fresh water. For different or corrosive liquids, contact GP Technical Service Department. With not clean liquids, appropriate filtration should be installed. Select the injector based on the nominal operating rating: system rated pressure, max flow and max temperature. Install valve with direction arrow pointing downstream. For proper operation a control device such as a dual lance wand, quick couple nozzles, or an adjustable nozzle holder must be used to lower the system pressure at the nozzle.

Under no circumstances should the pressure of the system exceed the maximum rated pressure of any component.

TROUBLESHOOTING

PROBLEM	CAUSE	SOLUTION
Injector will not draw liquid	Incorrect nozzle System is not in low pressure mode Discharge hose is too long Chemical line is clogged	Check and change nozzle Change or adjust nozzle to put system in low pressure mode Reduce length of discharge hose or change injector* Clear chemical line of obstruction
Rate of draw seems too slow	Discharge hose is too long Air leak in chemical line Chemical is too viscous	Reduce length of discharge hose or change injector* Locate and repair leak Reduce chemical with water to decrease its viscosity
Chemical injector is leaking from hose barb	Obstruction in hose barb check valve Damaged o-ring in check valve	Disassemble and remove obstruction Remove and replace o-ring
Excessive pressure load on pump, motor or engine	Clogged injector Improperly sized injector orifice	Clear injector orifice of obstruction Change orifice*

*Contact GP Technical Service for Assistance

WARNING: High Pressure Systems require a primary pressure regulating device (i.e. regulator, unloader) and a secondary pressure relief device (i.e. pop-off valve, relief valve). Failure to install such relief devices properly could result in personal injury or damage to pump or property. GP does not assume any liability or responsibility for the operation of the user's high pressure system.