**FEATURES**

- Direct-mount, control set unloader
- Used with 44, 47, 50, 60, 63 Series pumps
- Built-in bypass
- Sturdy steel and brass construction
- Adjustable locknut to control the maximum pressure
- Plastic adjustment knob (not pictured)

*General Pump recommends using a safety relief device in conjunction with this unloader valve when installed on a positive displacement pump. General Pump is not liable and assumes no responsibility when used in a customer's high pressure system.*

**SPECIFICATIONS**

Part Number	YVB35KDM	YVB35KDMI18	YVB35KDMI21
Max. Temperature	195° F <sup>1</sup>		
Max. Volume	6.5 GPM		
Rated Pressure	3,200 PSI		
Minimum Adjustable Pressure	319 PSI		
Maximum Discharge Pressure	3,650 PSI		
Pressure Drop to Reset Bypass	19% <sup>2</sup>		
Port Sizes:	Inlet	1/2" BSP-F	
	Outlet	3/8" BSP-M	
Injector	N/A	1.8 mm	2.1 mm
Overall Dimensions	5.9" x 3.0" x 1.75"		
Weight	1.8 lbs.	1.9 lbs.	
Materials	Brass, Stainless Steel, Buna-N		

<sup>1</sup> This unloader has been designed to operate at a continuous water temperature of 140°F. It can be operated for short periods at a maximum temperature of 195°F.  
<sup>2</sup> This is the pressure reduction necessary in comparison to the set up, in order that the valve brings back pressure in the circuit (% figures of the pressure set up).

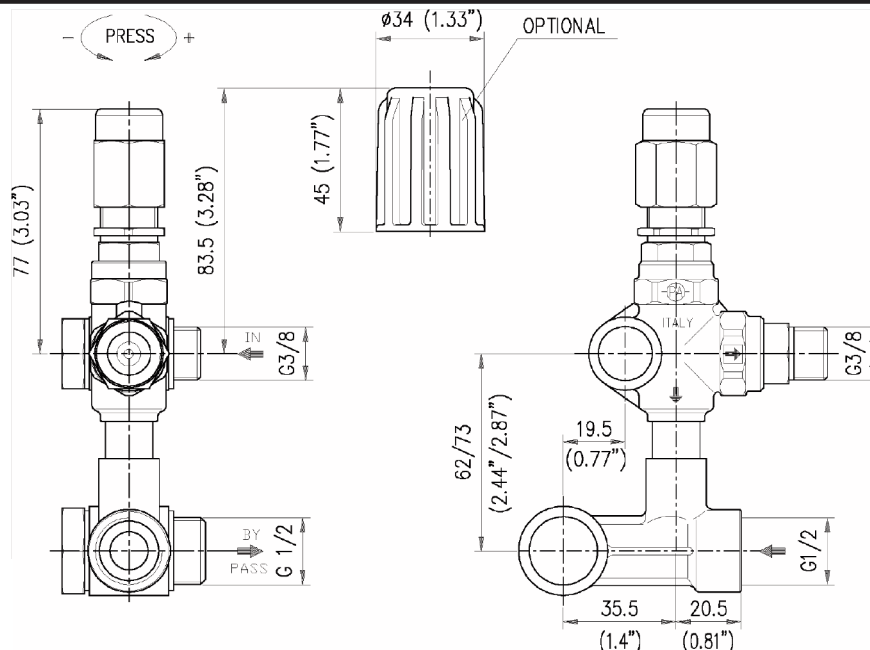
**DIMENSIONS**

 Ref 300991 Rev. A  
 02-16

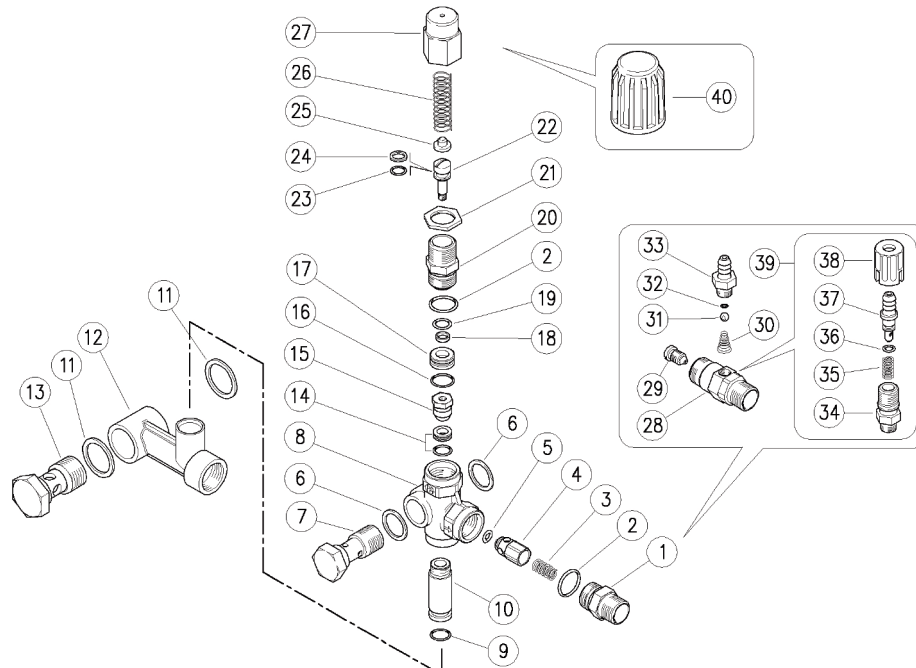
**PARTS LIST**



ITEM	PART #	DESCRIPTION	QTY	ITEM	PART #	DESCRIPTION	QTY
1	Y60190231	Shutter Coupling, 1/8M, Brass	1	22	Y60033199	Piston, M18 x 1, Brass	1
2*	701016	O-ring, 1.78 x 5.6	2	23*	701011	O-ring, 1.78 x 7.66, Buna-N	1
3	Y60086751	Spring, 0.5 x 6.5 x 22mm, SST	1	24*	Y10400800	Back-up Ring, Opn, 8 x 11 1.2 mm	1
4	Y60065999	Shutter Pin, Brass, + O-ring	1	25	Y60031061	Spring Guide, Zinc	1
5*	Y10312500	O-ring, 2.5 x 4	1	26	Y60086261	Spring, 3.0 X 12.6 X 41 mm, Zinc	1
6	Y14410000	Washer, Seal, 3/8 BSP	2	27	Y60030431	Valve Regulating Knob (Optional)	1
7	Y60080700	Pierced Delivery Screw, 3/8 BSP, Brass	1	28	Y21005731	Injector Housing	1
8	Y60086135	Valve Housing, Brass	1	29	Y21005451	Nozzle, M6 x1, 2.1 mm, SST	1
9	Y10310996	O-ring, 2.4 x10.3 mm	1	30	Y21016051	Tapered Spring, SST	1
10	Y60085331	Manifold Fitting, 150x42 mm	1	31	Y14742001	Ball, 7/32", SST	1
11	Y14410100	Washer, Seal, 1/2 BSP	2	32	701501	O-ring, 1.78 x 5.28 mm, Viton	1
12	Y60085135	Valve, Manifold, 1/2 F BSPO-ring, 1.78x7.66	1	33	Y21000331	Hose Barb, 8-12x1 mm, Brass	1
13	Y60080431	Pierced Screw, 1/2 BSP, 36.5 mm, Brass	1	34	Y21017661	Coupling, M12 x 1-1/14 BSP, Brass	1
14*	Y60087220	Seat, 7.5 mm + O-ring	1	35	Y21015851	Spring, 0.8 x 7 x 15 mm, SST	1
15*	Y60087121	Rest, M5, Brass + Ball, 118/32, SST	1	36	701008V	O-ring, 1.78 x 4.48 mmn Viton	1
16*	701014	O-ring, 1.78 x 12.42 mm	1	37	Y21045599	Hose Barb, d. 8 mm, Brass + O-ring	1
17	Y60086331	Spacer Ring, 6.2 x 16 x 6, Brass	1	38	Y21017184	Injector Knob, 1/4F BSP, Black	1
18*	Y10400600	Back-up Ring, 8.6 x 6 x 1.2	1	39	Y21010000	Regulator + Hose Barb	1
19*	Y10305101	O-ring, 1.78 x 6.07 mm	1	40	Y60031584	Valve Regulating Knob	1
20	Y30030331	Piston Holder, Brass	1				
21	Y60031731	Locknut, M18 x 1, Brass	1				
				*	Y60190624	Repair Kit	

**INSTRUCTIONS**

**SELECTION**

This product is to be used with clean water which can contain the addition of normal detergents. For use involving different or corrosive liquids, contact the General Pump Customer Service Department. Appropriate filtration should be installed when using water that may contain any sort of debris. Choose the valve appropriate for the system rated pressure, maximum flow rate and maximum temperature. In any case, the pressure of the machine should not exceed the permissible pressure rate imprinted on the valve.

**INSTALLATION**

On a system that produces hot water, this accessory must be fitted upstream of the heat generator. On a system that generates hot water, it is advisable to fit in accessories that limit the accidental increase of fluid temperature.

**ALWAYS INSTALL A SAFETY VALVE**

It is recommended to use a nozzle with a size that, at gun opened, allows to discharge from the valve bypass at least 5% of the flow supplied by the pump in order to obtain a constant pressure value, and an easy adjustment and to avoid troublesome pressure spikes at gun closure.

If the nozzle wears out, the working pressure decreases. To reset the pressure back to work level, it is necessary to replace the worn nozzle. When a new nozzle is fitted, re-setting of the system to its original working pressure is necessary.

**INSTRUCTIONS (cont.)****DISCHARGE SYSTEM AND WATER ADDUCTION**

We recommend to fit the valve with the bypass discharge returned to a tank. It is advisable that the tank be fitted with baffles to reduce eventual turbulence and air bubbles generated by the emission of the bypass flow which could be harmful for the pump. With elevated flow or near to the maximum flow of the valve, the installation with a recirculation of bypass direct to the pump could cause potential pressure spikes harmful to the pump.

**PRESSURE ADJUSTMENT/CALIBRATION**

The desired working pressure must be adjusted with the system running and the gun opened. Adjust the pressure by screwing or unscrewing the adjustment screw/knob. The operation is easier if the correct nozzle has been chosen (see paragraph "installation"). When screwing the screw/knob a consequent pressure increase must be matched. If, before reaching the desired pressure, there is no pressure increase when screwing the screw/knob, do not force but check the correct riation nozzle/flow rate - pressure and, if necessary, fit a nozzle with a smaller size.

**TROUBLESHOOTING**

<b>PROBLEMS</b>	<b>PROBABLE CAUSES</b>	<b>SOLUTIONS</b>
Frequent Unloader Cycles	Damaged check valve o-ring Leaking connections Restricted bypass	Replace Check and renew Clean or adapt
Unloader does not come up to pressure	Unloader not properly sized Piston O-rings worn out Debris between seat and shutter Worn nozzle	Change spring or type of valve Replace Clean the seat Replace
Excessive pressure spikes	There is not a minimum of 5% flow in bypass Excessive flow in bypass Spring totally compressed	Reset Change type of valve ar adjust passages Loosen knob and change nozzle
Unloader does not bypass at low pressure	Jammed check valve Check valve O-ring worn Debris in check valve	Clean or replace Replace Clean

**MAINTENANCE**

Maintenance must be carried out by Qualified Technicians.

**STANDARD:** Every 400 working hours (10,000 cycles), check and lubricate the seals with water resistant grease.

**SPECIAL:** Every 800 working hours (20,000 cycles), check the wear of the seals and internal parts and, if necessary, replace with original General Pump parts taking care during installation and to lubricate with water resistant grease.

**The manufacturer is not responsible for damage as a result of incorrect fitting and maintenance.**