



Pneumatically-Operated Pressure Regulator

FEATURES

- Available in 2 versions according to pressure and volume required.
- Allows remote control of the water pressure.
- Allows off-load start up.
- When there is no air pressure water flows through the by-pass without pressure.
- No discharge leakage in bypass.
- Suitable for controlling several units at the same time,



SPECIFICATIONS

Part Number	PN4S-200	PN4S-300
Max Volume	132 GPM	103 GPM
Max pressure	2,900 PSI	4,300 PSI
Max Fluid Temperature	140° F	
Inlet Port Thread	1-1/2" BSP-F	
Discharge Port Thread	1-1/2" BSP-F	
Bypass Port	1-1/2" BSP-F	
Air Inlet Port	1/4" BSP-F	
Max Air Pressure	101 PSI	
Air Consumption	28 n/liter/min	
Oil Capacity - oz / (liters)	8.5 / (.25) Hydraulic	
Weight	35.3 LBS	
Materials	Upper Body:	Aluminum Alloy
	Lower Body:	SPF600 Cast Iron
Valve & Seat Valve:	Stellite® Coated AISI 420 SS	

Specifications are subject to change without notice.

INSTALLATION DIAGRAMS

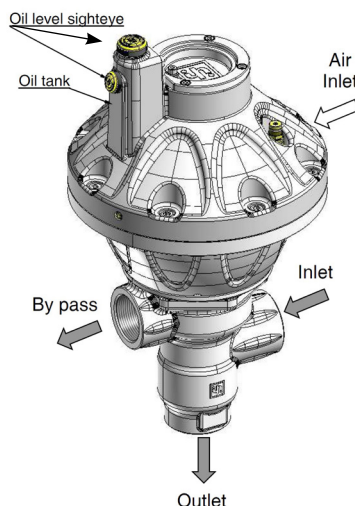

INDUSTRIAL

INDUSTRIAL



General Pump is a member of the Interpump Group



DIMENSIONS & INFORMATION

Inlet G1"1/2 – Outlet G1"1/2 – Bypass G1"1/2 – Air inlet G1/4

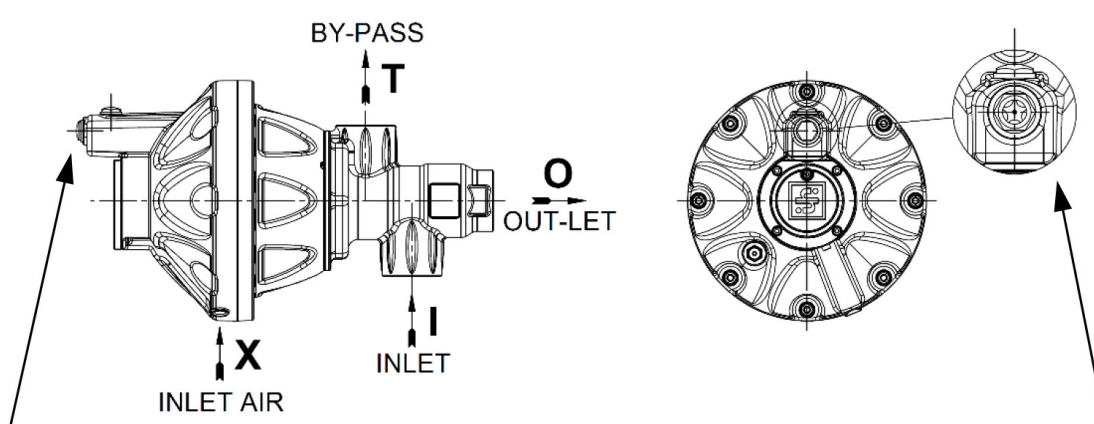
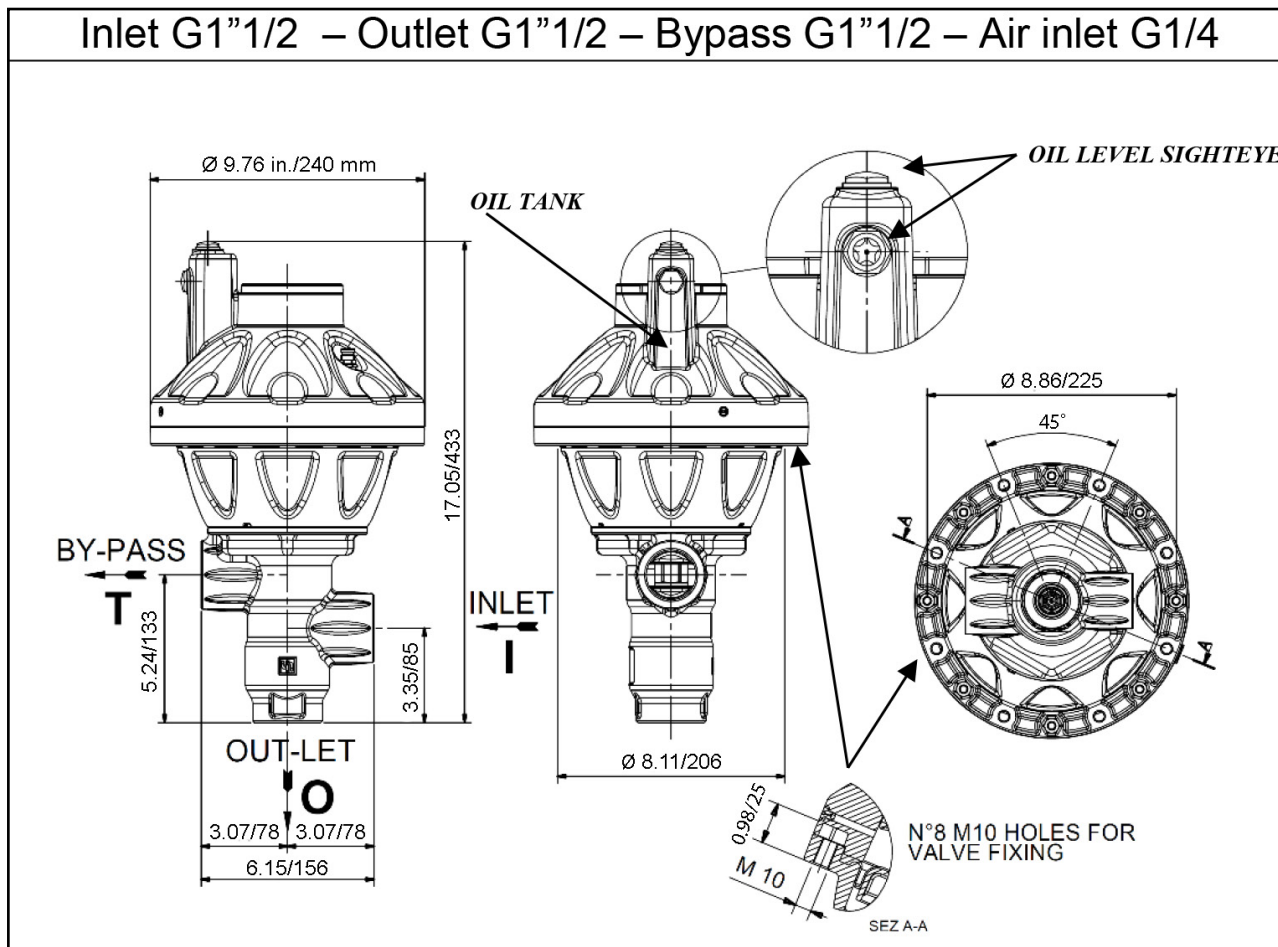

WARNING: The tank must always be oriented upwards. Make sure that the oil level is half the peephole.
WARNING: For other installation methods please contact GP's Customer Service.

PARTS LIST

No.	Part No.	Description	Qty.
1	F99153700	Screw, TCEI M5 x 12	10
2*	F96687500	Washer, Ø5 x 9 x 1.5	4
3	F36026705	Cover	4
4	F99367100	Screw, TECi M10 x 25	1
5*	F90446000	O-ring, Ø56.52 x 5.34	1
6	F36015062	Piston	1
7*	F36014655	Valve Seat Piston	1
8*	F36014555	Valve Plate	1
9*	F94730750	Spring, Ø0.4 x 11	1
10	F36016555	Spring Guide	1
11	F96692000	Washer, Ø5.5 x 20 x 1.5	4
12*	F90386100	O-ring, Ø26.65 x 2.62	4
13*	F90403500	O-ring, Ø15.47 x 3.53	2
14	F36016470	Guide Bushing	1
17	F97593000	Sight Glass	1
18	F36026822	Upper Body	1
19	F99308400	Screw, TCEI Ø8 x 30	8
20	F98642000	Jet, Ø0.40	1
21	F36349622	Closing Plug	1
22*	F90407700	O-ring, Ø44.45 x 3.53	1
23	F94776000	Spring, Ø0.69 x 80	1
24	F99372000	Screw, TCEI M10 x 45	6
25	F36015322	Lower Body	1
26	F92222300	Nut, M8-8	8
27*	F90445000	O-ring, Ø43.82 x 5.34	1
28	F36015756	Jacket	1
29*	F90398000	O-ring, Ø59 x 3	1
30	F36015805	Intermediate Ring	1
31	F36015956	Valve Seat, PN4-200	1
	F36016056	Valve Seat, PN4-300	1
32*	F90523000	Spiralback Ring, 40.8 x 46 x 1.5	1
33*	F90397300	O-ring, Ø40 x 3	1
34	F97675000	Spiral Pin	1
35	F36015405	Valve Body, LP	1
36	F98279750	Plate, PN4-200	1
	F98279850	Plate, PN4-300	1
37	F92237400	Nut, M10	1
38	F96712100	Washer, Ø10.5 x 21 x 2	2
39	F96729500	Washer, Ø14 x 38 x 4, INOX	2
40*	F36014882	Closing Plate	1
41	F36016256	Primary Control Rod	1
42	F36014907	Valve Tab	1
43*	F90382500	O-ring, Ø10.78 x 2.62	1
44*	F90520400	Spiralback Ring, 38 x 11.26 x 1.3	2
45*	F90406500	O-ring, Ø37.69 x 3.53	1
46	F36016370	Piston	1
47	F92202100	Nut, M6	6
48	F96735800	Washer, Ø16.2 x 80 x 4	1
49	F36014022	Membrane Support	1
50	F36014148	Membrane	1
51	F36013976	Membrane Plate	1
52	F99185200	Screw, M6 x 16	6
53*	F90384700	O-ring, Ø20.24 x 2.62	1
54	F36015656	Control Rod	1
55	F98872000	Safety Valve	1
56	F98643000	Jet, Ø0.70	1
57*	F90412500	O-ring, Ø71.44 x 3.53	1
58	F97666200	Spiral Pin	2
59	F87204030	Washer, Ø6 x 10 x 1.5	6
60	F99306900	Screw, M8 x 25, Zinc	5
*	F0303	Repair Kit	

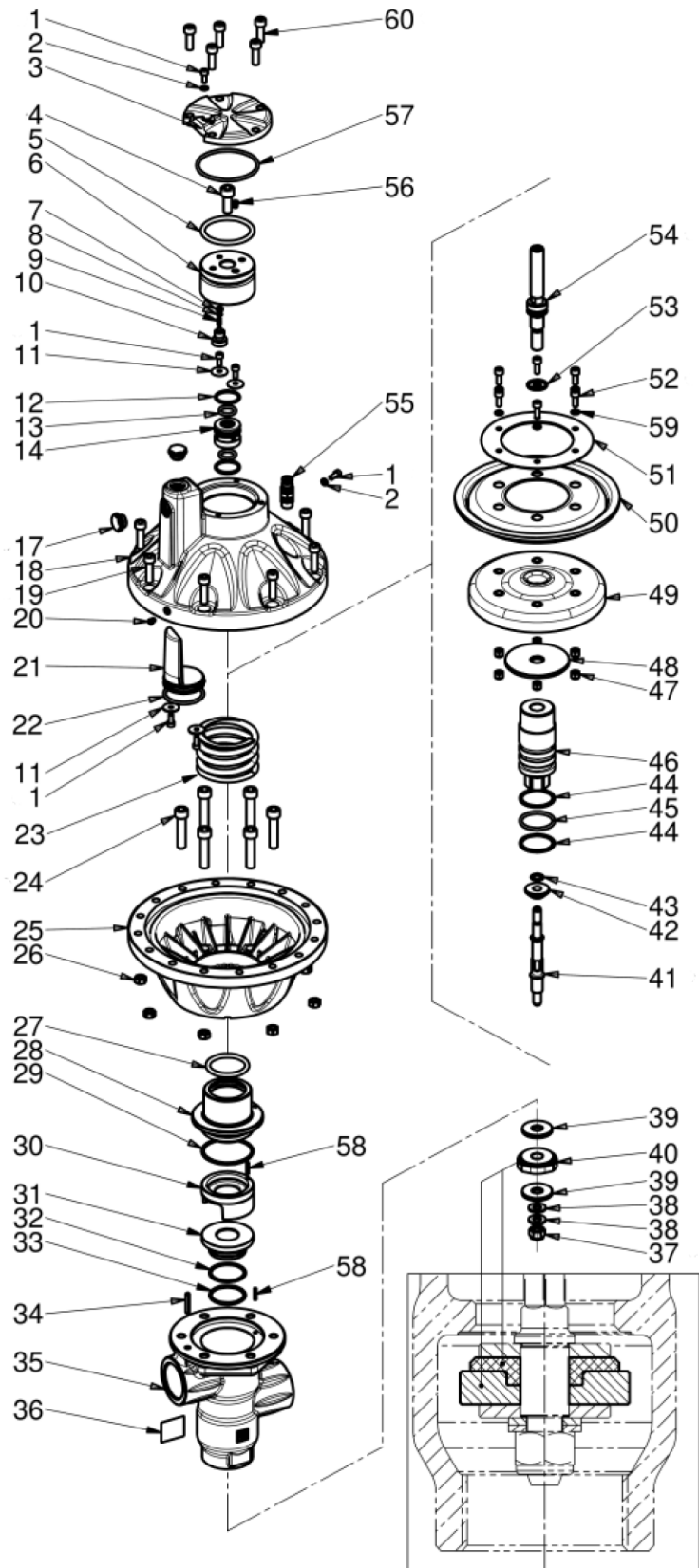

No.	Torque	No.	Torque
1	4.43 ft-lbs (6 Nm)	37	25.81 ft-lbs (35 Nm)
4	29.5 ft-lbs (40 Nm)	41	29.5 ft-lbs (40 Nm)
10	22.13 ft-lbs (30 Nm)	52	7.38 ft-lbs (10 Nm)
17	2.95 ft-lbs (4 Nm)	54	59.0 ft-lbs (80 Nm)
19	14.75 ft-lbs (20 Nm)	60	14.75 ft-lbs (35 Nm)
24	25.81 ft-lbs (35 Nm)		

INFORMATION

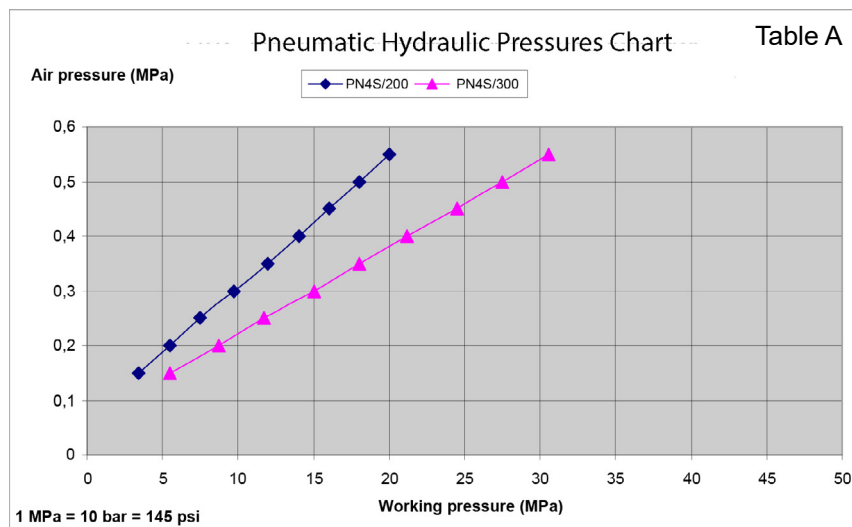

At the pneumatic pressure of 0.58 MPa the air consumption is 28 NI/min.

Air Valve Diagram

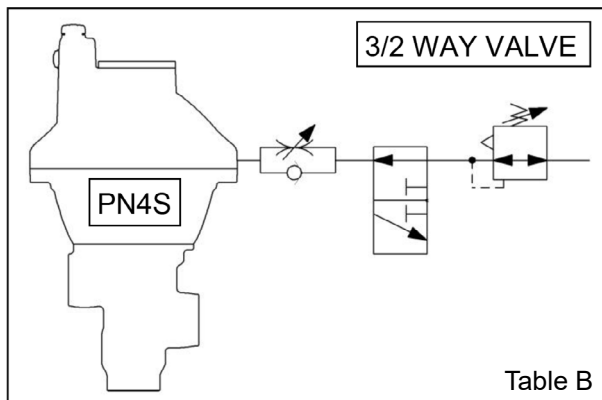

Valve Use Field Graph

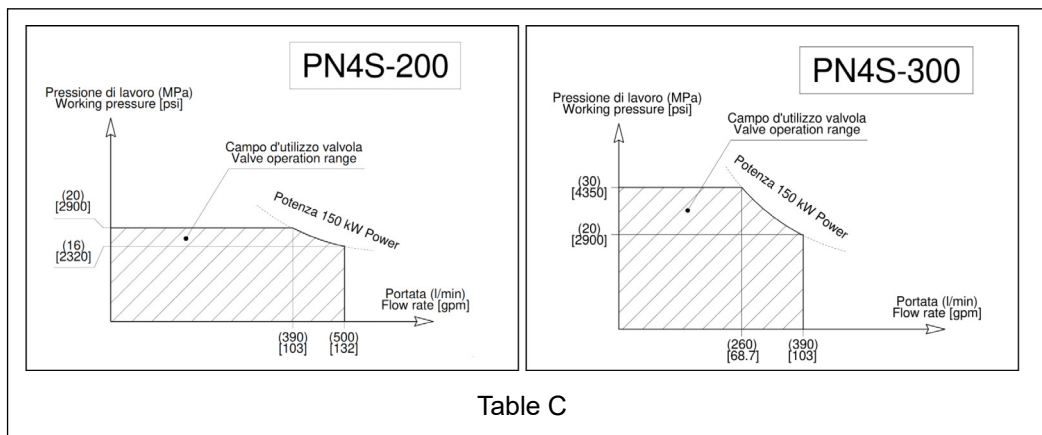

INSTALLATION AND INSTRUCTIONS FOR USE

THIS DOCUMENT PROVIDES THE INSTRUCTIONS FOR THE INSTALLATION, USE AND MAINTENANCE OF THE VALVE, THEREFORE IT IS AN INTEGRAL PART OF THE VALVE ITSELF AND MUST BE READ CAREFULLY BEFORE ANY USE AND KEPT WITH CARE.

STRICTLY COMPLY WITH THE INSTRUCTIONS CONTAINED IN THIS DOCUMENT IN VIEW OF A SAFE AND EFFECTIVE USE OF THE VALVE.

FAILURE TO COMPLY WITH THESE INSTRUCTIONS MIGHT CAUSE EARLY FAULTS AND RESULT IN SITUATIONS OF DANGER, IN ADDITION TO VOIDING ANY WARRANTY.

1. GENERAL INFORMATION

1.1 The **PN4S** pressure regulator is a manually adjustable, pressure-operated pneumatic-control device. According to its setting, limits the pumps/system pressure by conveying the excess of water to the by-pass. Moreover, when the outlet flow is blocked, this device totally releases the flow, thus keeping the pump/system at the adjusted pressure.

1.2- The pneumatic control of the valve allows to change the hydraulic working pressure by changing the air pressure. The two pressures are proportional, i.e. when increasing the pneumatic pressure the hydraulic pressure increases and when reducing the pneumatic pressure the hydraulic pressure decreases (see table A).

1.3- The pneumatic control of the valve allows it to cut in or to cut out the adjusted hydraulic pressure. This function is particularly suited for automatic working cycles and remote controls. When the pneumatic pressure is cut out, the pump starts at zero pressure, i.e. without the motor being under stress.

1.4- In order to operate the pneumatic control of the valve it is necessary to use compressed air with a value depending on the desired hydraulic pressure. In order to correctly operate the pneumatic control we suggest you use a 3/2-way valve and a pressure regulator as shown in the diagram (table B).

2- PACKAGE AND HANDLING

2.1-To ensure the tightness of the fittings used to connect the valve to the system, use a metal washer with a rubber ring or insert an appropriate sealing on the thread and tighten them to the torque indicated in the table.

THREADING	TORQUE (ft-lbs/Nm)
G1 1/2"	121.4 ft-lbs/540 Nm ±5%

2.2- In order to optimize the pump-valve coupling, it is necessary to keep the valve operation range, as a function of the pump pressure and flow rate, within a maximum power of 204 HP (150 kW). As shown in the chart (see Table C):

- **PN4S-200** this means using pumps producing a flow rate of approx. 103 GPM (390 l/min.) for maximum working pressures of 2900 psi (200 bar - 20 MPa), and generating a pressure of approx. 2320 psi (160 bar-16 MPa) for maximum flow rates of 132 GPM (500 l/min.).

- **PN4S-300** this means using pumps producing a flow rate of approx. 68.7 GPM (260 l/min.) for maximum working pressures of 4350 psi (300 bar - 30 MPa), and generating a pressure of approx. 2900 psi 20 MPa (200 bar-20MPa) for maximum flow rates of 103 GPM (390 l/min.).



Important: Please contact GP's Customer Service Department in case you should decide to use the valve in the "by-pass" mode by plugging the valve outlet with a cap.

3- INSTRUCTIONS FOR PRESSURE SETTING:

3.1- In order to obtain a correct adjustment and a proper functioning of the valve, always make sure that, when working at the maximum pressure, the valve by-pass keeps releasing a quantity of water equal to 5% of the total flow-rate. In case the flow-rate at the by-pass is close to zero or exceeds 15% of the maximum flow-rate, this could cause faults, early wear and result in situations of danger.

The positions mentioned in the following instructions refer to those shown in the Parts List and Exploded View

3.2- Connect the valve to the water system and to the pneumatic circuit and set it upright or horizontal (for other positions please contact the GP's Customer Service Department), then follow these steps:

3.3- Open the pneumatic pressure regulator completely in order to control the valve.

3.4- Start the hydraulic system on which the valve is fitted and make sure that the air contained in it is fully ejected.

3.5- Open the gun or the water control device. Start the pneumatic circuit and begin adjusting the air pressure within the valve by using the pneumatic pressure regulator. Alternate the adjusting operations with a few openings and closings of the gun or of the control device. When the desired hydraulic pressure has been reached, open and close the gun/control device a few times again in order to stabilize the various components (seals, springs etc.). Check the pressure value again and correct if necessary.

3.6- In case you decide to change the adjusted hydraulic pressure later, follow the procedure stated in paragraph 3.2.3 again.

3.7- The upper body pos. 18 is equipped with a safety valve pos. 55 in order to limit the pneumatic pressure within the valve and with a permanently open breather nozzle pos. 20 in order to regulate the functioning (air consumption). The installer must adjust the safety valve so that it opens when the pneumatic pressure is approx. 10% higher than the pneumatic pressure necessary to obtain the maximum desired hydraulic pressure.

3.8- The maximum pneumatic pressure allowed within the valve must not exceed 0.7 MPa (7.0 bar).

4- MAINTENANCE

4.1- From time to time, check the oil window pos. 17 to verify the oil level. If necessary, add the oil by the cap pos.17 up to the middle of the oil window.

4.2- From time to time, it is necessary to check that the valve is clean outside, and that there is no sign of oil or water leakage and/or malfunctioning. If necessary, replace the involved parts. In case of doubts, contact GP's Customer Service Department.

INSTALLATION AND INSTRUCTIONS FOR USE

4.3- The valve contains approx. 0.25 litres of high-viscosity hydraulic oil (cSt 40°C=44.2) containing addition agents used to grant higher performances, with an excellent level of protection against wear and high oxidation and corrosion strength. It is possible to use other oils having similar features provided that they are VG 46 DIN 51519 ISO quality (or with 15W-20 SAE degree).

4.4- The exhausted oil must be gathered in containers and disposed of contacting the authorized facilities as established by local laws. The oil must not be dispersed in the environment for any reason.

In case of doubts, do not hesitate to contact GP's Customer Service Department.



IMPORTANT: During use, never exceed the maximum values of pressure (of water and air), flow-rate and temperature as stated in this document and/or indicated on the valve.

WARNING: High Pressure Systems require a primary pressure regulating device (i.e. regulator, unloader) and a secondary pressure relief device (i.e. pop-off valve, relief valve). Failure to install such relief devices properly could result in personal injury or damage to pump or property. GP does not assume any liability or responsibility for the operation of the user's high pressure system.



WARNING: This product can expose you to chemicals including lead, which is known to the state of California to cause cancer and birth defects or other reproductive harm. For more information, go to www.P65Warnings.ca.gov