

FEATURES

- Oversized roller bearings
- Fully anodized crankcase
- Innovative new seal design extends seal life
- New plunger design improves thermal shock resistance
- New valve cap improves hydrostatic performance
- Nickel-plated manifold
- Nickel-plated valve plugs

**SPECIFICATIONS**

Pump Model	TSF2019N	TSF2019N (Alternate Spec)
Maximum Volume	7.6 GPM	6.3 GPM
Maximum Discharge Pressure	3600 PSI	
Horsepower	18.7 EBHP	15.5 EBHP
Maximum Pump Speed	1750 RPM	1450 RPM
Maximum Inlet Pressure	125 PSI	
Maximum Inlet Vacuum	9 ft. water / 7.9 in. Hg	
Plunger Bore (in / mm)	.787 in. / 20 mm	
Plunger Stroke (in / mm)	.748 in. / 19 mm	
Oil Capacity	37.2 oz.	
Maximum Fluid Temperature	165° F	
Inlet Port Thread	3/4"-14 BSP-F	
Discharge Port Thread	3/8"-19 BSP-F	
Shaft Diameter (in / mm)	.945 in. / 24 mm	
Weight	40.7 lbs / 18.5 kg	
Dimensions	14.94" x 9.78" x 6.99"	



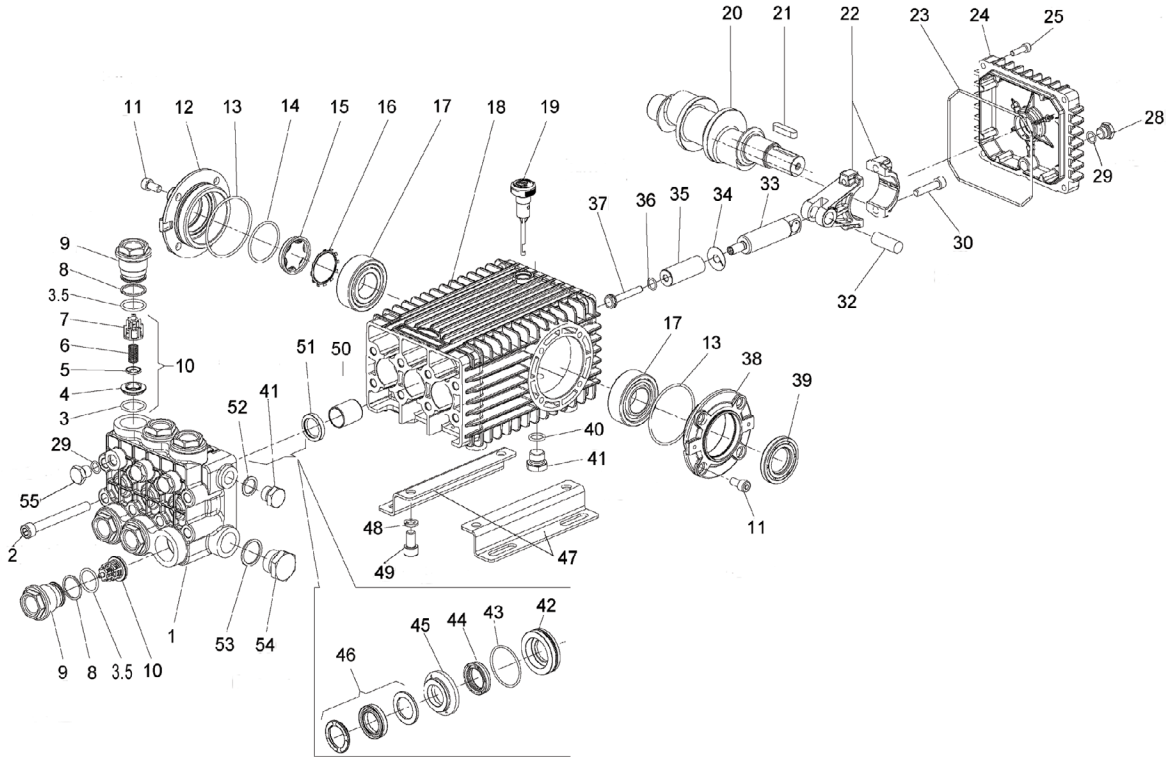

PARTS LIST

POS.	PART NO.	DESCRIPTION	QTY.	POS.	PART NO.	DESCRIPTION	QTY.	POS.	PART NO.	DESCRIPTION	QTY.
1	66120641	Manifold, Ø 20mm	1	19	98210600	Dipstick, vented	1	39	90164800	Seal, Shaft	1
2	99380100	Headbolt M10 x 90	8	20	66020035	Crankshaft, 19mm Stroke	1	40	90383300	O-ring, Ø 13.95x2.62	1
3	90385700	O-ring, Ø 23.81x2.62	12	21	91489200	Key, 8x7x35	1	41	98209900	Plug 3/8 x 13, Nickel	2
4	36203366	Valve Seat	6	22	66030001	Connecting Rod, Complete	3	42	66080070	Seal Retainer, Ø 20mm	3
5	36203476	Valve Poppet	6	23	90392200	O-ring, Ø133.02x2.62	1	43	90361600	O-ring, Ø 34.65x1.78	3
6	94738800	Valve Spring Ø10x18x18.5	6	24	66160022	Rear Cover	1	44	90269000	LP Seal, Ø 20mm	3
7	36203551	Valve Guide	6	25	99188400	Screw, M6x20	4	45	66216070	Intermediate Ring, Ø 20mm	3
8	90516500	Anti-ext ring Ø24.7x29x1.5	6	26	90405100	O-ring, 26.58x3.53	1	46	90269200	HP Seal, Ø 20mm	3
9	66130341	Plug, M32x1.5x29.5	6	27	63210051	Oil Level Indicator	1	47	47200074	Pump Rail	2
10	36712701	Valve Assy., Complete	6	28	98204100	Plug, G1/4"x9	1	48	96710600	Washer M10	4
11	99303900	Screw M8 x 16	8	29	701013	O-ring, Ø .426x.070	4	49	99364400	Screw M10 x 18	4
12	47151222	Cover	1	30	99309900	Screw, M8x35	6	50	90912600	Guide Bushing	3
13	701147	O-ring, Ø67.95x2.62	2	32	97740500	Wrist Pin, 14x39	3	51	90162500	Seal, Plunger Rod	3
14	90387700	O-ring, Ø 39.34x2.62	1	33	66050064	Piston Guide	3	52	96738000	Gasket, Aluminum 3/8"	1
15	70211801	Oil Sight Glass	1	34	96710100	Flinger Washer	3	53	96770000	Washer	1
16	90075600	Retainer Clip	1	35	66040009	Plunger, Ø 20mm	3	54	98226900	Plug, G3/4"x16, Nickel	1
17	91838000	Bearing	2	36	90358400	O-ring, Ø 10.82x1.78	3	55	98204700	Plug 1/4" x 13, Nickel	3
18	66010022	Crankcase	1	37	66219566	Plunger Bolt	3				
				38	47151022	Side Cover, PTO	1				

REPAIR KITS

KIT NO.	K02	K03	K169	K170	K171
POS. NO's INCLUDED IN KIT	51	39	3, 4, 5, 6, 7 (10)	44, 46	42, 43, 44, 45, 46
NUMBER OF ASSEMBLIES IN KIT	3	1	6	3	1
NUMBER OF CYLINDERS KIT WILL SERVICE	3	N/A	3	3	1

TORQUE SPECS*

POS.	Nm	Ft/lb
2	45	33.2
9	130	95.9
11	20	14.8
25	10	7.4
28	20	14.8
30	20	14.8
37**	20	14.8†
41	40	29.5
49	40	29.5
54	70	51.6
55	40	29.5

* Decrease torque by 20% if threads are lubricated

** Use Loc-Tite 542 or similar

OIL CHANGING

1. Oil changing must be done with the pump at operating temperature.
- 1.2 Put a container under the oil drain plug (3).
- 1.3 Remove the oil dipstick (1) and then the drain plug (3).
- 1.4 Wait until all the oil has drained out, then screw the drain plug (3) and tighten at the torque shown in the exploded diagram and above table.
- 1.5 Fill with new oil (General Pump Series 100) until the middle of the oil sight glass is reached, screw by hand the oil dipstick (1).

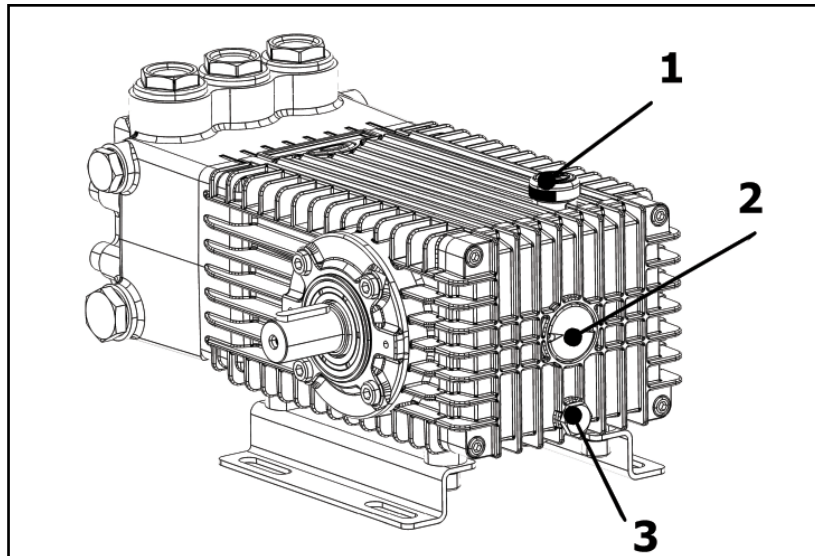

WARNING: High Pressure Systems require a primary pressure regulating device (i.e. regulator, unloader) and a secondary pressure relief device (i.e. pop-off valve, relief valve). Failure to install such relief devices properly could result in personal injury or damage to pump or property. GP does not assume any liability or responsibility for the operation of the user's high pressure system.



WARNING: This product can expose you to chemicals including lead, which is known to the state of California to cause cancer and birth defects or other reproductive harm. For more information, go to www.P65Warnings.ca.gov