



### SPECIFICATIONS

PART NUMBER	DHRHC50100
3/8" Hose Capacity	100 ft.
1/4" Hose Capacity	150 ft
Pressure Rating	5,000 PSI
Inlet	3/8" NPT-M
Outlet	3/8" NPT-F
Max. Temp	250° F

### FEATURES / BENEFITS

- Direct hand-crank rewind with locking pin
- Stainless steel Frame
- Durable powdercoated finish (reel)
- 100' Capacity for 3/8" Hose
- 150' Capacity for 1/4" hose
- 5,000 PSI
- 3/8" NPT-M inlet (1/2"NPT-M adapter included)
- 3/8" NPT-F outlet

### PARTS LIST

No.	PART No.	DESCRIPTION	QTY
1	2103152	FRAME KIT, HAND CARRY, SS	1
2	2540011	ASSY, FLANGE, 100'	1
3	2540001	PIN, LOCK	1
4	2720004	SPRING	1
5	2200032	RING	1
6	2203403	WASHER	2
7	2530025	BUSHING	2
8	2720010	SPRING	1
9	2203416	WASHER, SWIVEL	1
10	2103130	SWIVEL, HOSE REEL, FORGED	1
11	100056	HANDLE KIT	1
12	2660385	PLUG	1
13	2702005	GUARD, HOSE	1
14	2530112	FITTING, 1/2NPT-MX3/8NPT-F	1
15	2400004	DECAL, GP	1
16	2200166	BOLT, M10X25, SS	4
17	2203017	NUT, M10, NYLOK, SST	4
18	2203413	WASHER, FLAT, M10	8
19	2103150	ARM, ASSY 100'	1
<b>REPLACEMENT PARTS / KITS</b>			
1	2100580	COLLAPSIBLE FRAME KIT, SS	1
10	2103130	SWIVEL, HOSE REEL, FORGED	1
11	100056	HANDLE KIT	1
14	2530112	FITTING, 1/2NPT-MX3/8NPT-F	1
	2100278	SWIVEL REPAIR KIT	1
	2100530	SPRING LOCK KIT	1
	2660216	HANDLE GRIP, Ø 32 MM	1

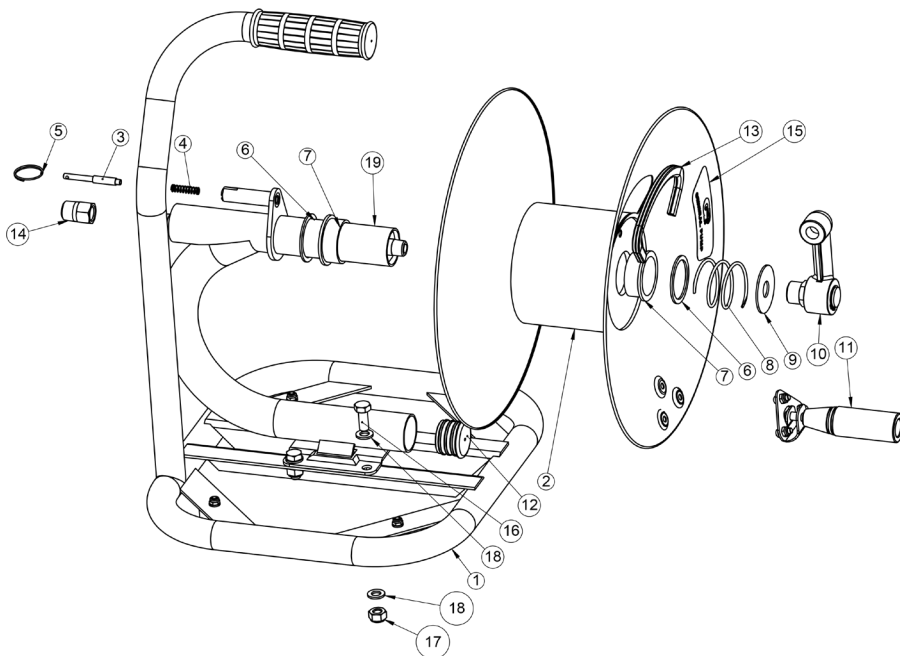

### DIMENSIONS

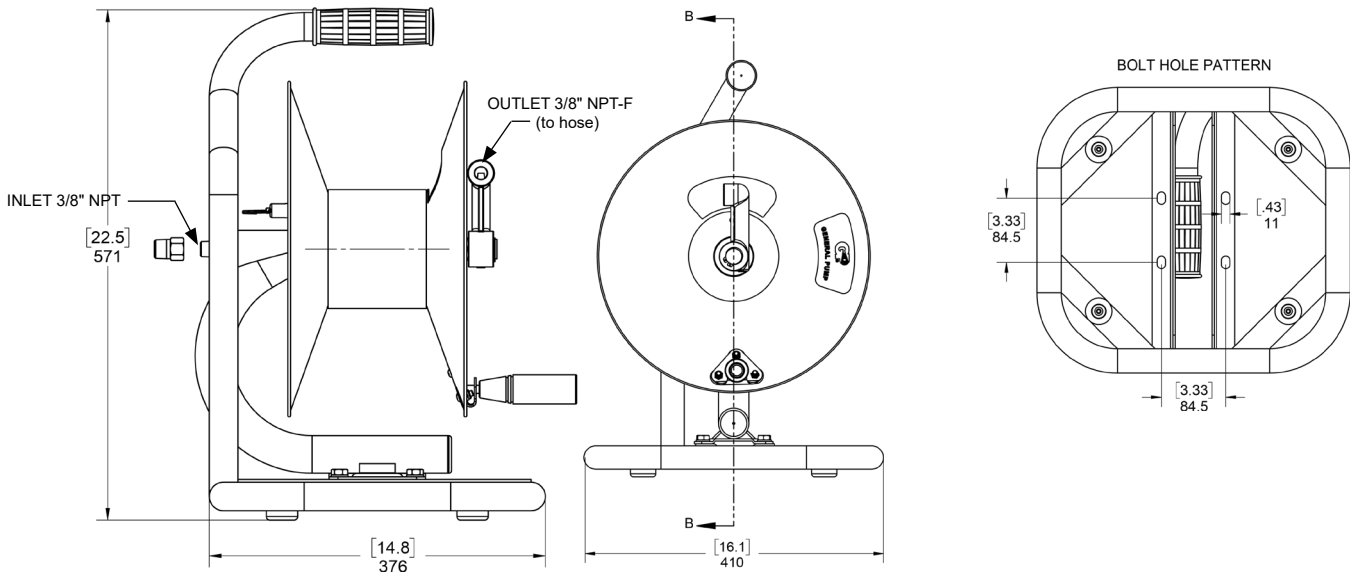

### OPTIONAL ACCESSORIES

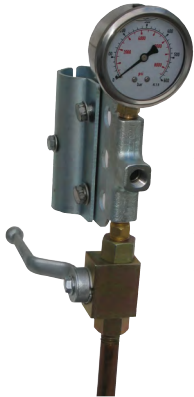

- Glycerin Filled Gauge
- Full Flow Ball Valve
- 5000 PSI
- 1/4" NPT-F Inlet
- 1/4" NPT-F Outlet

**PRESSURE DROP: DHRHC50100 & 2100012**

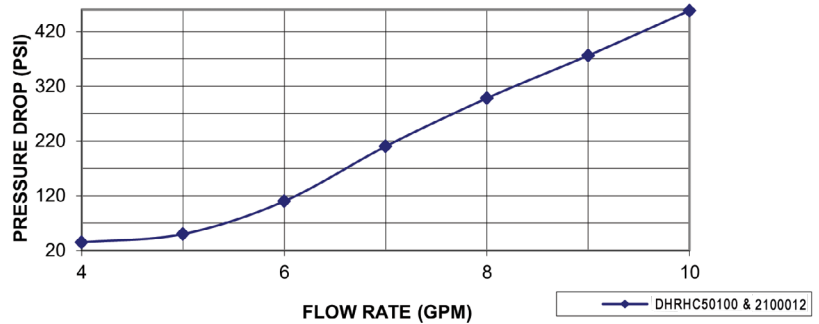

**\*\*NOTE:** 2100012 is an optional hardware kit.

1. Clamp the hardware kit to the hose reel handle with the two M8 bolts.
2. Use thread sealant (not provided) and the supplied fittings/adapters as needed to connect an inlet hose (not provided) to the hardware kit inlet.
3. Use thread sealant on the hose reel pigtail and connect to the hardware kit outlet.
4. The hardware kit may be used to turn flow on or off to the hose reel and to monitor pressure and flow in the hose reel.
5. Two different length U-bolts are supplied with the hardware kit for attaching the hose reel as needed to a truck or cart.

### SAFETY PRECAUTIONS

1. Make sure incoming pressure does not exceed the rated pressure.
2. Use proper eye protection when assembling and using the hose reel.
3. Assemble the hose reel on a clean workbench free of debris and moisture.
4. Keep children away from work area.

**WARNING:** High Pressure Systems require a primary pressure regulating device (i.e. regulator, unloader) and a secondary pressure relief device (i.e. pop-off valve, relief valve). Failure to install such relief devices properly could result in personal injury or damage to pump or property. GP does not assume any liability or responsibility for the operation of the user's high pressure system.



WARNING: This product can expose you to chemicals including lead, which is known to the state of California to cause cancer and birth defects or other reproductive harm. For more information, go to [www.P65Warnings.ca.gov](http://www.P65Warnings.ca.gov)

### **WARNING!**

*Exposure of skin directly to pressurized air or fluids could result in severe bodily injury!*