

FEATURES

- Flanged for direct couple to gasoline engines (SAE J609)
- Set screw for key way
- Oversized bearings
- Longer life low and high pressure seals
- Forged brass manifold with an exclusive lifetime warranty

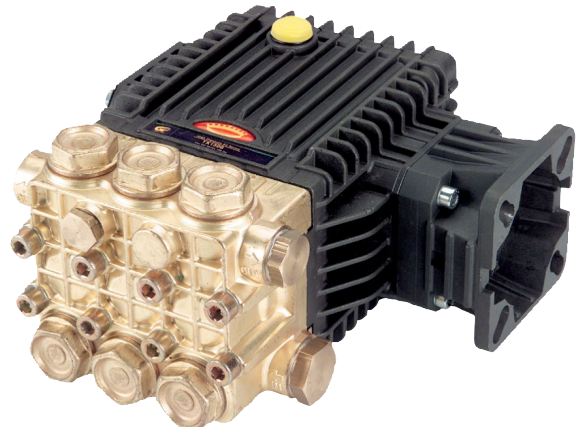

SPECIFICATIONS

Pump Model	TX1505G6	TX1506G6	TX1508G6
Maximum Volume	2.0 GPM	2.6 GPM	3.0 GPM
Maximum Discharge Pressure	3000 PSI		
Horsepower	6.2 GBHP	8.0 GBHP	9.2 GBHP
Maximum Pump Speed	3400 RPM		
Maximum Inlet Pressure	125 PSI		
Minimum Inlet Pressure	Flooded		
Plunger Bore	.591 in. / 15 mm		
Plunger Stroke	.197 in. / 5 mm	.256 in. / 6.5 mm	.315 in. / 8 mm
Oil Capacity	14.0 oz.		
Maximum Fluid Temperature	165° F		
Inlet Port Thread	1/2-14 BSPP-F		
Discharge Port Thread	3/8-19 BSPP-F		
Shaft Diameter	3/4 in. / 19 mm		
Weight	18 lbs.		
Dimensions	8.4" x 8.4" x 4.8"		

DIMENSIONAL DRAWING

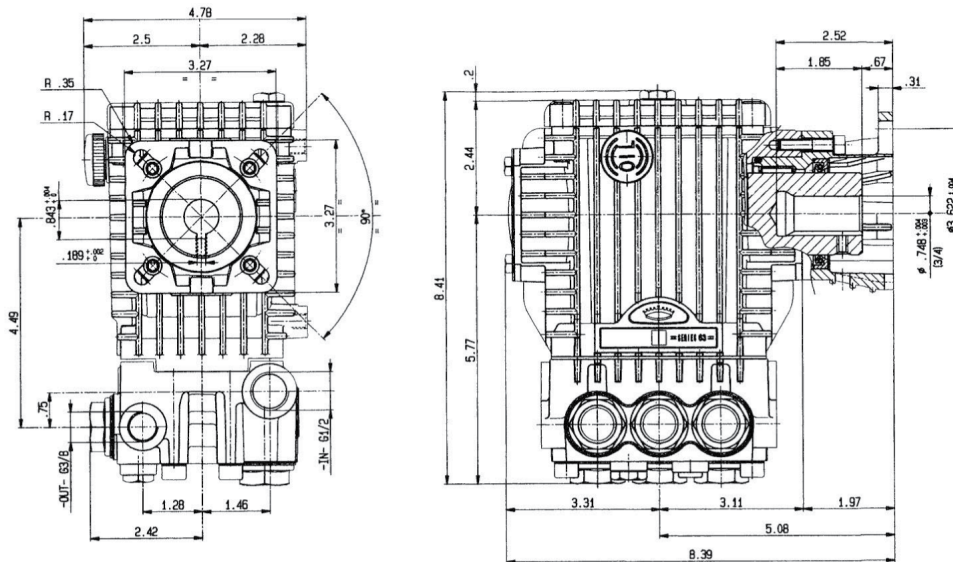

TRIPLEX

TRIPLEX

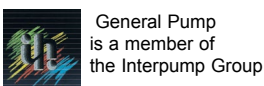

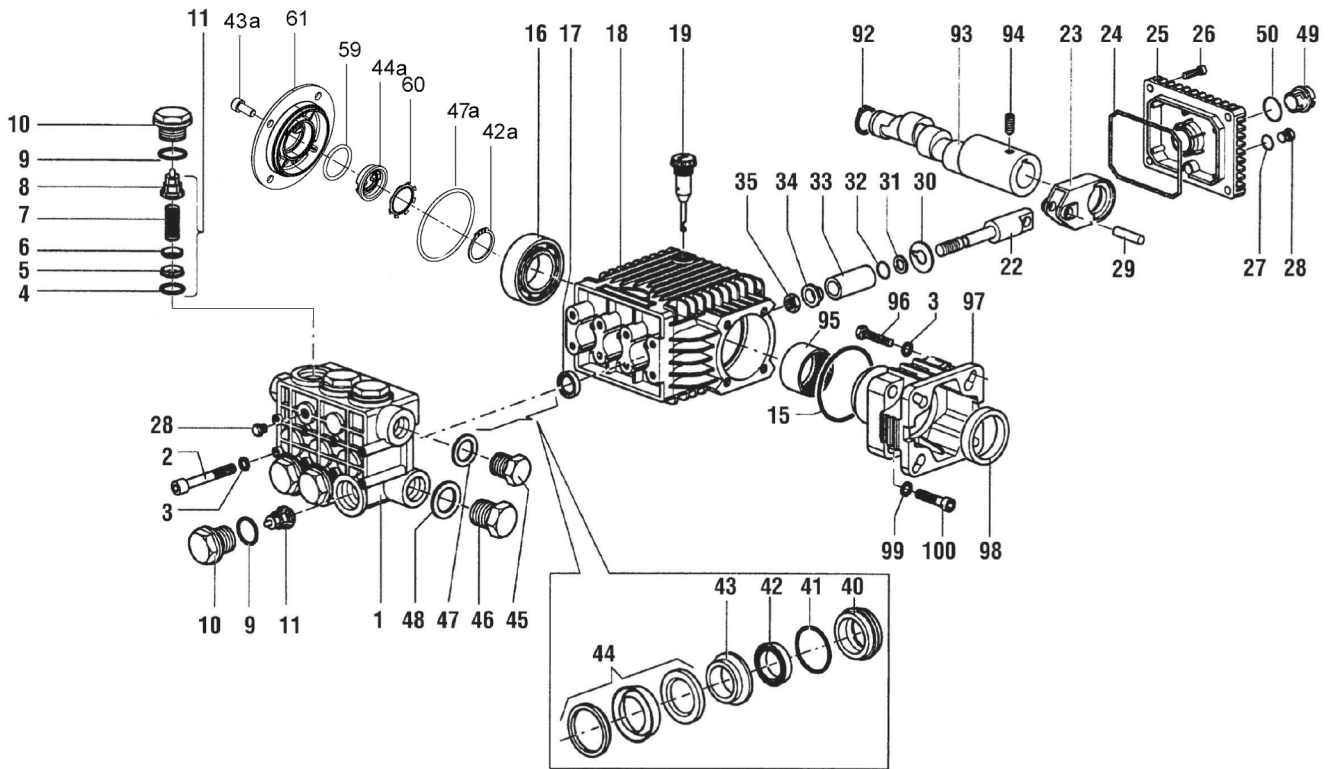

PARTS LIST

ITEM	PART NO.	DESCRIPTION	QTY.	ITEM	PART NO.	DESCRIPTION	QTY.	ITEM	PART NO.	DESCRIPTION	QTY.
1.	63120041	Manifold, 15 mm	1	27.	701013	O-ring	1	47a.	90389800	O-ring Ø 56.82x2.62	1
2.	99319200	Screw, M8 x 65	8	28.	98204100	Plug, 1/4" G	2	48.	96751400	Washer, M21.5	1
3.	96701400	Lockwasher, M8.4	8	29.	97733500	Connecting Rod Pin	3	49.	63210051	Oil Level Indicator	1
4.	701115	O-ring	6	30.	96707500	Flinger Washer	3	50.	90405100	O-ring	1
5.	36200366	Valve Seat	6	31.	660024	Anti-extrusion Ring	3	59.	90385900	O-ring Ø 56.82x2.62	1
6.	36200176	Valve Plate	6	32.	701009	O-ring	3	60.	90067100	Stop Ring	1
7.	94737600	Spring	6	33.	52040009	Ceramic Plunger, 15mm	3	61.	58150122	Side Cover	1
8.	36202551	Valve Cage	6	34.	44211570	Bushing	3	92.	90063500	Retaining Ring	1
9.	701002	O-ring	6	35.	92221600	Nut, M8	3	93.	63026265	Crankshaft, 5 mm	1
10.	98222600	Valve Cap	6	40.	63080070	Seal Retr'n, 15mm	3		63026465	Crankshaft, 6.5 mm	1
11.	36711501	Valve Assembly	6	41.	90360800	O-ring	3		63026665	Crankshaft, 8 mm	1
16.	91832900	Ball Bearing	1	42.	90260800	Seal, LP,15mm	1	94.	99179000	Screw, M6 x 6	1
17.	90159500	Oil Seal	3	42a.	90063500	Stop Ring Ø 25	3	95.	91856800	Roller Bearing	1
18.	63010022	Crankcase	1	43.	63216070	Int. Ring,15mm	3	96.	99273000	Screw, 5/16" x 3/4"	4
19.	98210300	Oil Dip Stick	1	43a.	99183700	Screw M6x14	8	97.	10061722	Flange	1
22.	63050066	Plunger Guide	3	44.	90261200	Packing Assy,15mm	3	98.	90168700	Oil Seal	1
23.	63030022	Connecting Rod	3	44a.	53210851	Oil Level Indicator	1	99.	203510	Washer	4
24.	90392000	O-ring, Cover	1	45.	98210000	Plug, 3/8" G	1	100.	99191200	Screw, M6 x 30	4
25.	63160022	Rear Crankcase Cover	1	46.	98217600	Plug, 1/2" G	1				
26.	99183700	Screw, M6 x 14	4	47.	96738000	Washer, M17.5	1				

* 53150001 Oil Level Indicator Assembled W/O Screws and O-ring

REPAIR KITS

KIT NO.	123	124	159	160	162	164	166
ITEM NO's INCLUDED IN KIT	4, 5, 6, 7, 8 (11)	9, 10	17	42, 44	40	43	40, 41, 42, 43, 44
NUMBER OF ASSEMBLIES IN KIT	6	6	3	3	3	3	1
NUMBER OF CYLINDERS KIT WILL SERVICE	3	3	3	3	3	3	1

TORQUE SPECS*

Pos.	Ft/lb	Nm
2	14.7	20
10	95.9	130
12	7.3	10
26	7.3	10
28	14.7	20
35	11.0	15
45	29.4	40
46	29.4	40
59	14.7	20
64	7.3	10

* Decrease torque by 20% if threads are lubricated

