

FEATURES

- The preferred pump frame in the pressure cleaning industry
- Forged brass manifold with an exclusive lifetime warranty
- Large-capacity, die-cast, anodized aluminum oil-bath crankcase
- Over-sized connecting rods for maximum life
- Heavy-duty tapered roller bearing.
- Solid ceramic plungers with continuously lubricated packings
- Unitized stainless steel inlet and discharge valves
- Available in left-handed "L" version



SPECIFICATIONS

Pump Model	T9281-N
Maximum Volume	4.0 GPM
Maximum Discharge Pressure	4000 PSI
Maximum Pump Speed	1750 RPM
Maximum Inlet Pressure	125 PSI
Maximum Inlet Vacuum	9 ft. water (7.9 in. Hg)
Bore	.630 in. / 16 mm
Stroke	.630 in. / 16 mm
Crankcase Oil Capacity	40.6 oz.
Maximum Fluid Temperature	165°F
Inlet Port Thread	1/2-14 BSPP-F
Discharge Port Thread	3/8-19 BSPP-F
Shaft Diameter.	.945 in. / 24 mm
Weight	33 lbs.
Dimensions	12.6 x 9.2 x 6.9 in.

N=Nickel-plated manifold

DIMENSIONAL DRAWING

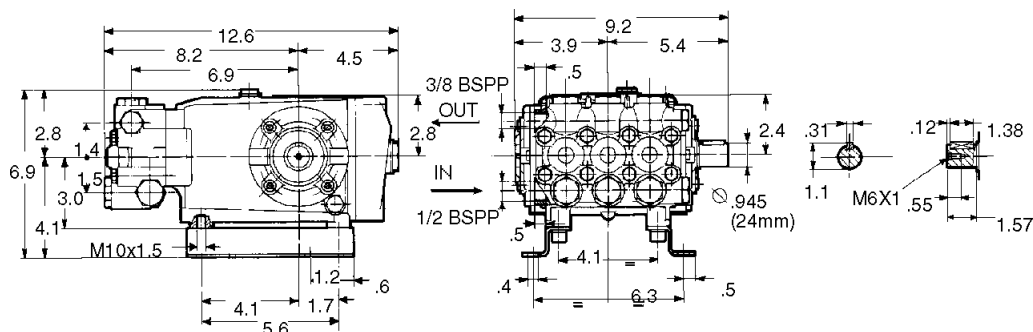

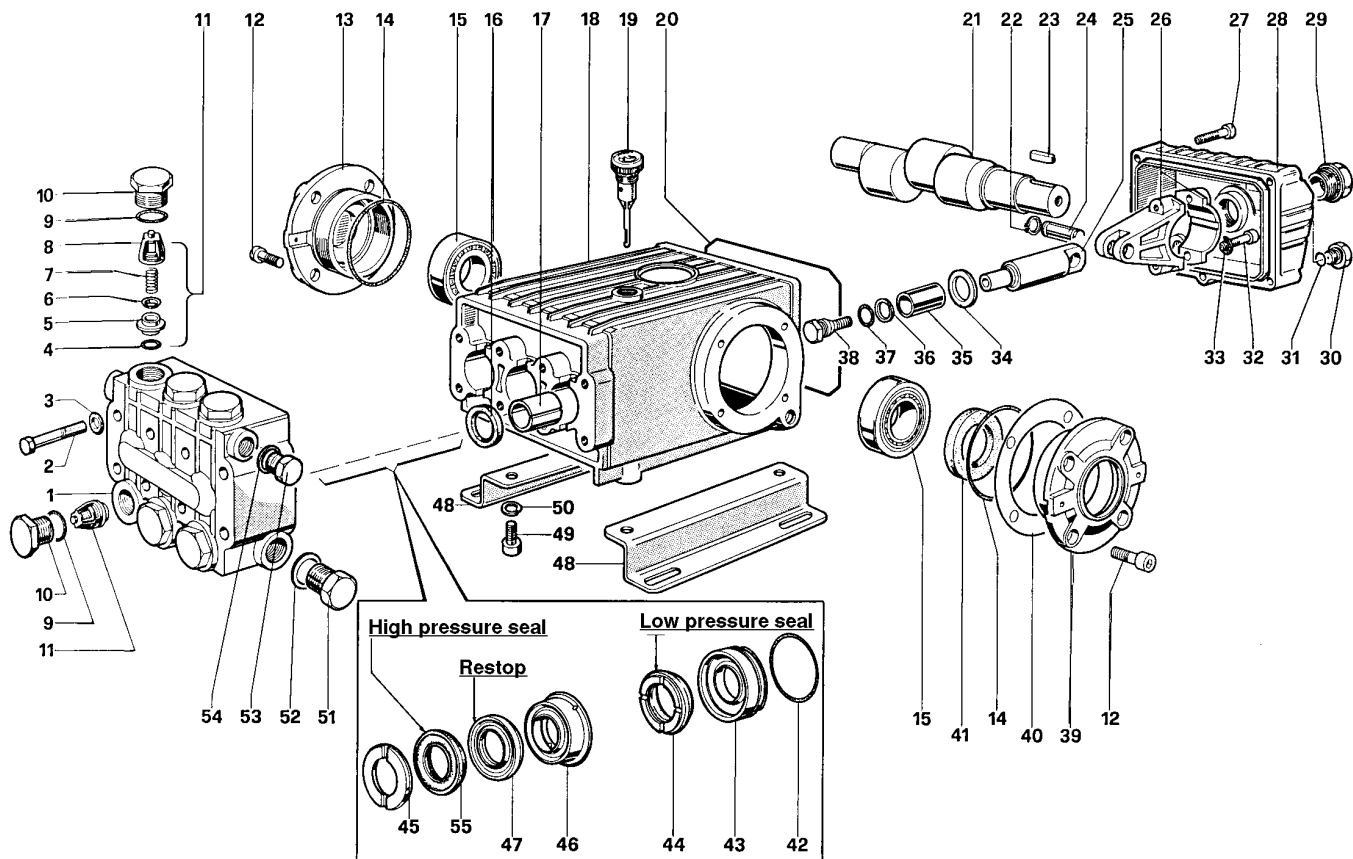

PARTS LIST

ITEM PART NO.	DESCRIPTION	KIT NO.	QTY.	ITEM PART NO.	DESCRIPTION	KIT NO.	QTY.	ITEM PART NO.	DESCRIPTION	KIT NO.	QTY.	
1	47.1214.41	Manifold	1	19	98.2106.00	Cap	1	38	47.2196.66	Plunger Screw	107	3
2	99.3206.00	Screw	8	20	90.3922.00	O-Ring, Cover	1	39	47.1500.22	Crankcase Cover		1
3	96.7020.00	Washer	8	21	47.0217.35	Crankshaft	1	40	97.5678.00	Shim		2
4	90.3841.00	O-Ring	1	22	90.0557.00	Cir-Clip	6	41	90.1648.00	Ring	3	1
5	36.2003.66	Valve Seat	1	23	91.4890.00	Key	1	42	90.3616.00	O-Ring	111,112	3
6	36.2001.76	Valve	1	24	97.7380.00	Plunger Pin	3	43	47.0808.70	Packing Retainer	111,112	3
7	94.7376.00	Spring	1	25	47.0506.54	Plunger Guide	3	44	90.2644.00	Seal, Low Press., 16mm	109,112	3
8	36.2002.51	Valve Guide	1	26	47.0300.01	Connecting Rod	3	45	47.1003.51	Head Ring	108,112	3
9	90.3847.00	O-Ring	106	27	99.1912.00	Screw	5	46	47.2172.70	Intermed. Ring	110,112	3
10	98.2224.00	Cap	106	28	47.1601.22	Crankcase Cover	1	47	90.2643.00	Restop Ring	109,112	3
11	36.7032.01	Valve Unit	1	29	97.5968.00	Oil Indicator	1	48	47.2000.74	Foot		2
12	99.3039.00	Screw	8	30	98.2041.00	Cap	1	49	99.3644.00	Screw		4
13	47.1501.22	Crankcase Cover	1	31	90.3585.00	O-Ring	1	50	96.7106.00	Washer		4
14	90.3913.00	O-Ring	2	32	99.3099.00	Screw	6	51	98.2176.00	Cap		1
15	640047	Bearing	2	33	96.7014.00	Washer	6	52	96.7514.00	Washer		1
16	90.1625.00	Ring	2	34	47.2117.47	Ring	107	53	98.2100.00	Cap		1
17	90.9126.00	Bushing	3	35	47.0408.56	Plunger (16 mm)	3	54	96.7380.00	Washer		1
18	47.0102.22	Crankcase	1	36	90.5033.00	Anit-Ext. Ring	107	55	90.2642.00	Packing	109,112	3
				37	90.3577.00	O-Ring	107					

REPAIR KITS

KIT NO.	1	2	3	106	107	108	109	110	111	112
ITEM NO.s INCLUDED IN KIT	4, 5, 6, 7, 8, (11)	16	41	9, 10	34, 36, 37, 38	45	44, 47, 55	46	42, 43	42, 43, 44, 45, 46, 47, 55
NUMBER OF ASSEMBLIES IN KIT	6	3	2	6	3	6	3	3	3	1
NUMBER OF CYLINDERS KIT WILL SERVICE	6	3	2	6	3	6	3	3	3	1

TORQUE SPECS*

Position	Ft.-lbs.
2	22.1
10	73.7
12	14.7
27	7.3
29	13.2
30	14.7
32	14.7
38	14.7
49	29.4
51	29.4
53	29.4

*Decrease torque by 20% if threads are lubricated.